

T S R Q P O N M L K J I H G F E D C B A

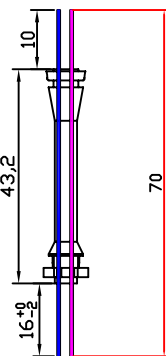

空心管SR2 (24.4mm)

WIRE CONNECTION

P1	COLOR	P2
1	RED	OPEN
2	WHITE	OPEN
3	GREEN	OPEN
4	BLACK	OPEN

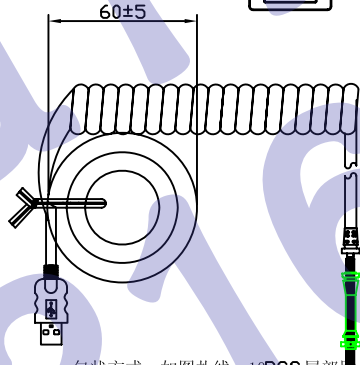

包状方式：如图扎线。10PCS尾部用PE膜包好。250PCS一箱，每层用珍珠棉隔开。

TEST REQUEST:

- 1.OPEN SHORT 100%
- 2.CT ≤ 2Ω IS ≥ 5MΩ
- 3.HV:DC 300V TIME: 0.1SEC

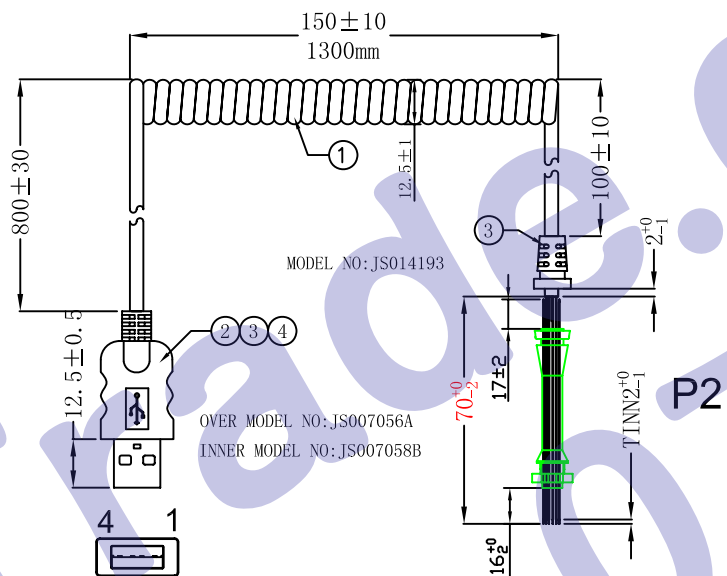

ITEM LIST

NO.	ITEM	DESCRIPTION	AMOUNT
①	CABLE	弹弓线 NOUL 22# (15/0.15TS+250D)*2C (RED, BLACK ) +28# (12/0.10TS+250D)*2C (WHITE, GREEN) OD:3.5±0.1mm JACKET PU COLOR: IPHONE5/WHITE 劈面 L=2330mm	1PCS
②	CONN	USB A/M POM WHITE SHEEL NI (短体)	1PCS
③	PVC	45P PVC COLOR:WHITE	9g
④	PE	LD-PE	5g
⑤	MINI TIE	L=70mm WHITE OVAL TIE	1PCS

DRAWN BY	Famous
CHECKED	
APPROVED	

CUSTOMER	
TITLE	USB AM TO OPEN
SHEET: 1/1	DRAWING NO: JS003317 (2)
UNIT: mm	DATE: APR-08-2015
THIRD ANGLE PROJECTION	REV. 2X

1X	ORIGINAL	APVD	ECD NO.
REV	DESCRIPTION		

-TOLERANCES-	
XX±0.5	XX±0.10
ANGLES ±5	

1  
2  
3  
4  
5  
6  
7  
8  
9  
10  
11  
12  
13  
14