

□ : TERMINAL NO. ○ : ITEM NO.

Model No.	DC00170- <u>H</u>	DC00170- <u>I</u>	DC00170- <u>J</u>
PIN	ø2.0	ø2.35	ø2.5

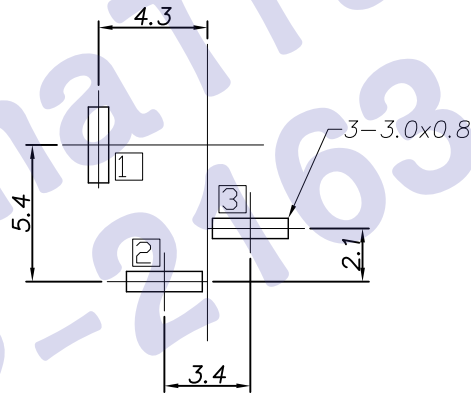
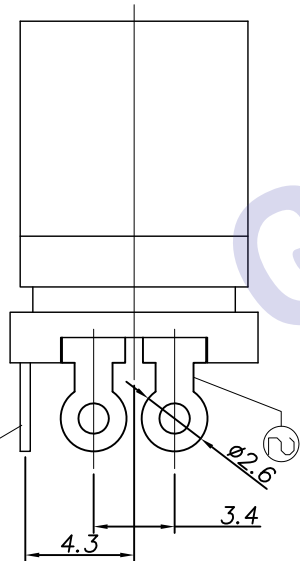

P.C.B Layout
(Printed-sidedview)

SPECIFICATION

1. Rating : DC 30V 2A;
2. Contact resistance: ≤30mΩ;
3. Insulation resistance: ≥100MΩ (DC250V);
4. Withstand voltage: 500VAC ;
5. Insertion and extraction force: 3-30N;
6. life test: 5,000 cycles.

6	Shunt terminal	1	Brass t=0.35	Cu/Sn-Plating
5	Tip spring	1	Bronze t=0.25	Cu/Sn-Plating
4	Center pin terminal	1	Brass t=0.35	Cu/Sn-Plating
3	Center pin	1	Brass	Ni-Plating
2	Cover	1	Bakelite	Yellow
1	Housing	1	ABS	Black

NO.	DESCRIPTION	QTY	MATERIAL	PLATING		
UNIT:MM	TYPE:	MODEL NO:	PAPER NO: A4	PAGE 1 OF 1		
	DC POWER JACK	DC00170- ____	TOLERANCE	ANGLES	SCALE	VER
			±0.3	±2'	FULL	2

DESIGNER BY:	YUJUN 2007.6.23
CHECK BY:	
APPROVED BY:	

HDC有限公司