

P.C.B  
LAYOUT  
VIEW

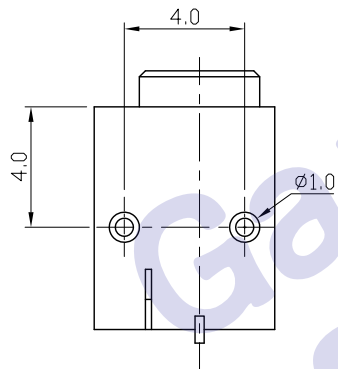

SCHEMATIC

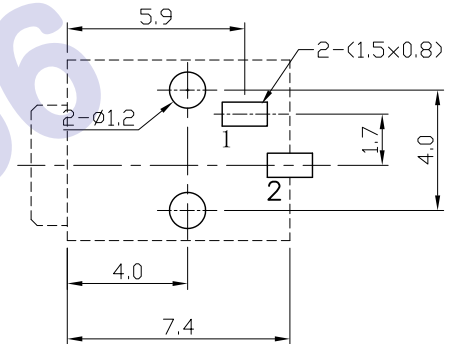
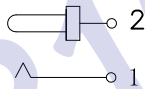

SPECIFICATION

1. Rating : DC 30V 0.5A;
2. Contact resistance:  $\leq 50\text{m}\Omega$ ;
3. Insulation resistance:  $\geq 100\text{M}\Omega$  (DC250V);
4. Withstand voltage: 500VAC ;
5. Insertion and extraction force: 3-30N;
6. life test: 5,000 cycles.

3	HOUSING	1	PA46/PBT	
2	PIN	1	BRONZE	Au-Plating
1	SPRING	1	STAINLESS STEEL	Au-Plating
NO.	DESCRIPTION	QTY	MATERIAL	PLATING
UNIT: MM	TYPE:	MODEL NO.:	PAPER NO: PAGE 1 OF 1	
	DC POWER JACK	DC00480-X	TOLERANCE: $\pm 0.3$	ANGLES: $\pm 2'$
DESIGNER			SCALE: 1:1	VER: 1
CHECK			<b>HDC有限公司</b>	
APPROVED				