

RoHS Compliant

更改 REV	设计内容 MODIFICATION	日期 DATE	制图 DRAW	核准 APPROVE
A	图面发行	2012/10/29	JY LEE	HERMAN

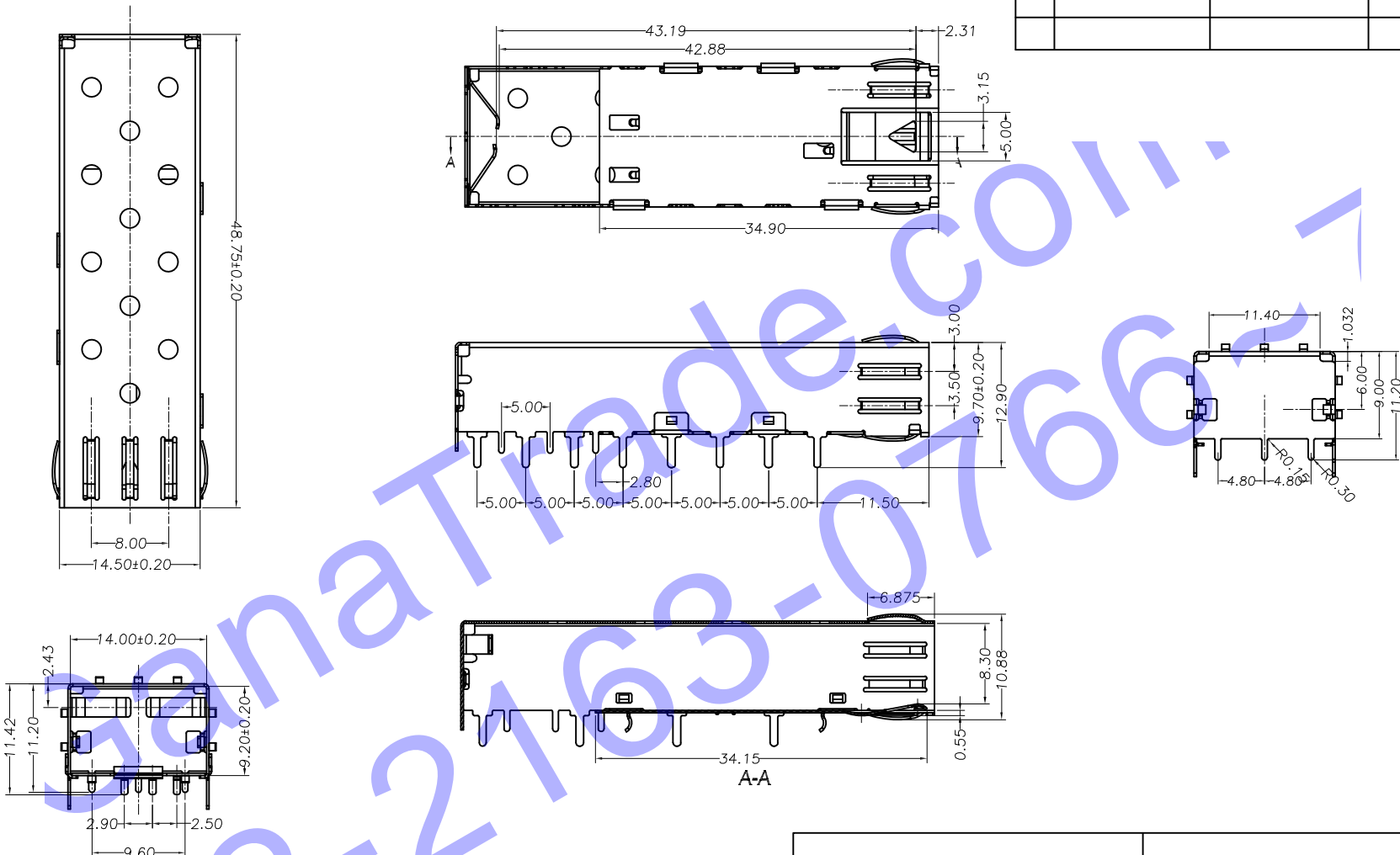

NOTES:
 MECHANICAL:
 CAGES: COPPER ALLOY, THICKNESS 0.25MM.
 PLATING: NO NEED.
 THIS CAGE IS FOR SINGLE SIDE USE ONLY.
 TEMPERATURE:
 OPERATION: -40°C~+85°C
 STORAGE: -40°C~+85°C
 RoHS COMPLIANCE.

QC : Inspection Item	CPK Control Item	DIMENSION IN mm [Inch]		H D C 有限公司	
		TOLERANCE UNLESS OTHERWISE SPECIFIED		料号 PART NO:	图号 DWC NO.
		.X± 0.20	X.*± 1°	SFP-1X1-L0-D	H7309
		.XX± 0.15	.X.*± 0.5°	名称 TITLE	
.XXX± 0.075		SFP CAGE 1X1 DIP FIT			
核准 APPROVE	审核 CHECK	制图 DRAW	角法 PROJ.	图例 SCALE	页次 SHEET
		JY LEE	第一角法 1:1	1:1	1 / 1
			比例 SCALE	图例 SIZE	更改 REV
			1:1	A3	A

RoHS Compliant

更改 REV	变更内容 MODIFICATION	日期 DATE	制图 DRAW	核准 APPROVE
A	图面发行	2012/10/29	JY LEE	HERMAN

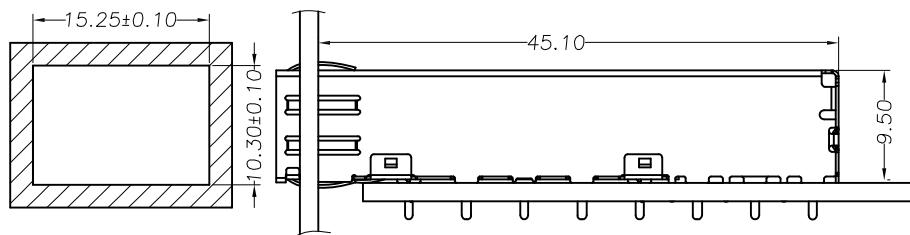

SUGGESTED PANEL CUTOUT DIM

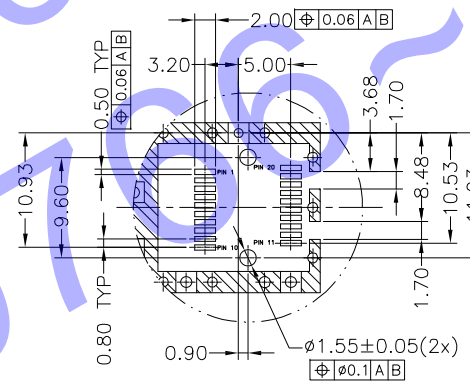

DETAIL C

CROSS-HATCHED AREA DENOTES COMPONENT AND TRACE KEEP-OUT (EXCEPT CHASSIS GROUND)

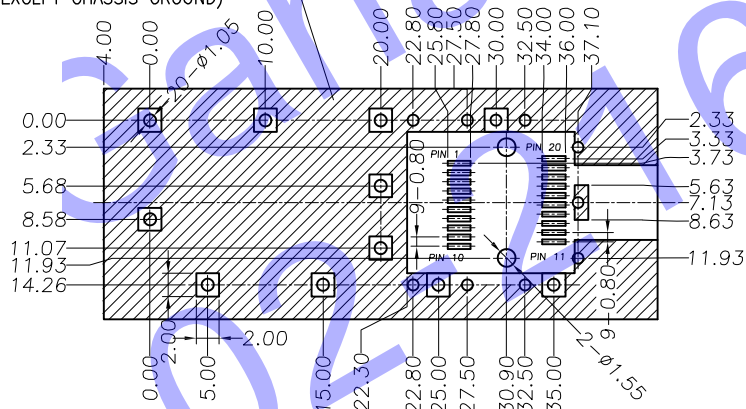

PC Board Layout

②② : Inspection Item ②③ : Cp/Cpk and SPC Control Item ②④ : Control Item	DIMENSION IN mm [Inch]		HDC 有限公司	
	TOLERANCE UNLESS OTHERWISE SPECIFIED		料号 PART NO:	图号 DWG NO.
	.X± 0.20	X.*± 1°	SFP-1X1-L0-D	H7309
	.XX± 0.15	.X*± 0.5°	名称 TITLE SFP CAGE 1X1 DIP FIT	
	.XXX± 0.075		制图 DRAW	角法 PROJ. JY LEE
核准 APPROVE	审查 CHECK	比例 SCALE 1:1	图纸 SIZE A3	页数 SHEET 1 / 1
			更改 REV A	