

# 0.5-11-立贴正脚承认图面

REV.	DESCRIPTION	DATE
A/0	原始版本	2011.05.10
A/1	8号尺寸原2.8±0.1改为2.65±0.15	2014.06.10

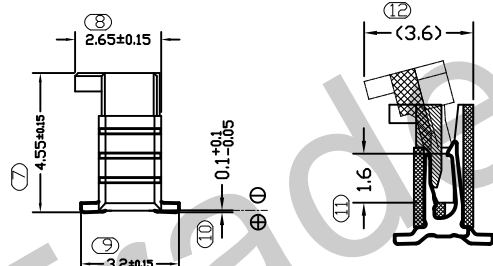

SECTION A-A

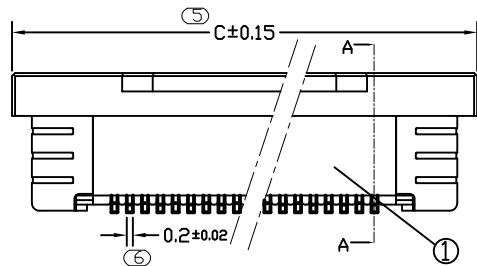
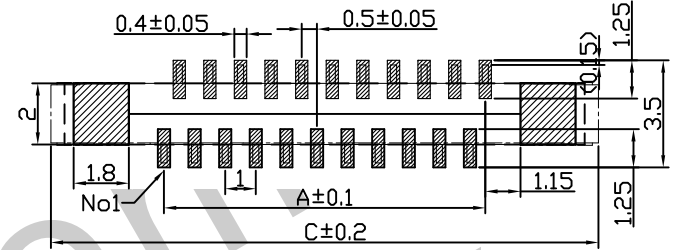
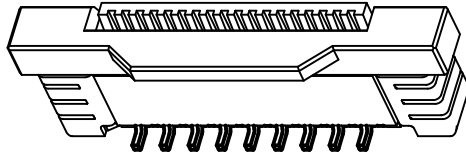
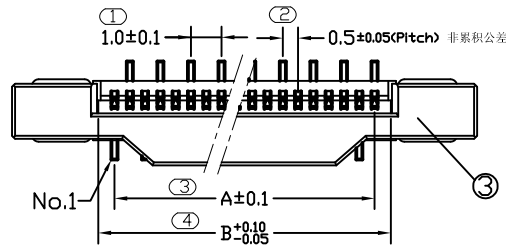
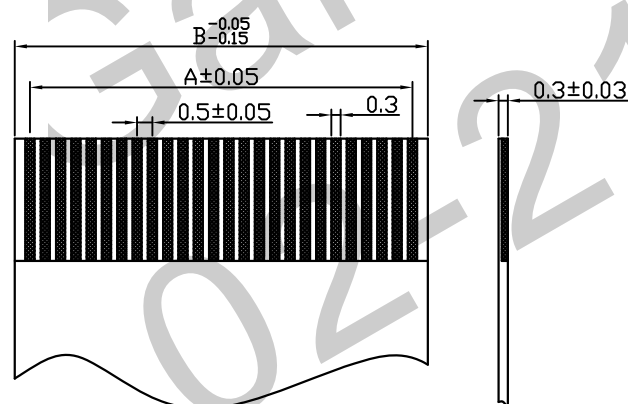
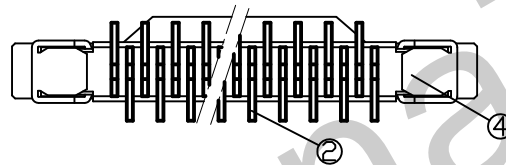

### 技术指标:

- 1、塑件表面应光洁、无毛刺、明显收缩、缺陷、裂纹等现象;
- 2、温度范围: -25°C~85°C;
- 3、额定电压: 50V, AC, DC(等效);
- 4、接触电阻: ≤0.03Ω;
- 5、绝缘电阻: ≥500MΩ;
- 6、耐压: 500V, AC/minute.

### ROHS管理规定:

- 1、禁止使用含有ROHS指令所限制的物质。
- 2、对应的SGS或ITS出具的ICP-AES数据、不可测定物质的成分表, 有效期一年。

### 适用线路板 RECOMMENDED PCB LAYOUT

Pin位	Type	A	B	C	Pin位	Type	A	B	C
4	0.5-11-4PLB(A)	1.5	2.6	8.2	33	0.5-11-33PLB(A)	16	17.1	22.7
5	0.5-11-5PLB(A)	2	3.1	8.7	34	0.5-11-34PLB(A)	16.5	17.6	23.2
6	0.5-11-6PLB(A)	2.5	3.6	9.2	35	0.5-11-35PLB(A)	17	18.1	23.7
7	0.5-11-7PLB(A)	3	4.1	9.7	36	0.5-11-36PLB(A)	17.5	18.6	24.2
8	0.5-11-8PLB(A)	3.5	4.6	10.2	37	0.5-11-37PLB(A)	18	19.1	24.7
9	0.5-11-9PLB(A)	4	5.1	10.7	38	0.5-11-38PLB(A)	18.5	19.6	25.2
10	0.5-11-10PLB(A)	4.5	5.6	11.2	39	0.5-11-39PLB(A)	19	20.1	25.7
11	0.5-11-11PLB(A)	5	6.1	11.7	40	0.5-11-40PLB(A)	19.5	20.6	26.2
12	0.5-11-12PLB(A)	5.5	6.6	12.2	41	0.5-11-41PLB(A)	20	21.1	26.7
13	0.5-11-13PLB(A)	6	7.1	12.7	42	0.5-11-42PLB(A)	20.5	21.6	27.2
14	0.5-11-14PLB(A)	6.5	7.6	13.2	43	0.5-11-43PLB(A)	21	22.1	27.7
15	0.5-11-15PLB(A)	7	8.1	13.7	44	0.5-11-44PLB(A)	21.5	22.6	28.2
16	0.5-11-16PLB(A)	7.5	8.6	14.2	45	0.5-11-45PLB(A)	22	23.1	28.7
17	0.5-11-17PLB(A)	8	9.1	14.7	46	0.5-11-46PLB(A)	22.5	23.6	29.2
18	0.5-11-18PLB(A)	8.5	9.6	15.2	47	0.5-11-47PLB(A)	23	24.1	29.7
19	0.5-11-19PLB(A)	9	10.1	15.7	48	0.5-11-48PLB(A)	23.5	24.6	30.2
20	0.5-11-20PLB(A)	9.5	10.6	16.2	49	0.5-11-49PLB(A)	24	25.1	30.7
21	0.5-11-21PLB(A)	10	11.1	16.7	50	0.5-11-50PLB(A)	24.5	25.6	31.2
22	0.5-11-22PLB(A)	10.5	11.6	17.2	51	0.5-11-51PLB(A)	25	26.1	31.7
23	0.5-11-23PLB(A)	11	12.1	17.7	52	0.5-11-52PLB(A)	25.5	26.6	32.2
24	0.5-11-24PLB(A)	11.5	12.6	18.2	53	0.5-11-53PLB(A)	26	27.1	32.7
25	0.5-11-25PLB(A)	12	13.1	18.7	54	0.5-11-54PLB(A)	26.5	27.6	33.2
26	0.5-11-26PLB(A)	12.5	13.6	19.2	55	0.5-11-55PLB(A)	27	28.1	33.7
27	0.5-11-27PLB(A)	13	14.1	19.7	56	0.5-11-56PLB(A)	27.5	28.6	34.2
28	0.5-11-28PLB(A)	13.5	14.6	20.2	57	0.5-11-57PLB(A)	28	29.1	34.7
29	0.5-11-29PLB(A)	14	15.1	20.7	58	0.5-11-58PLB(A)	28.5	29.6	35.2
30	0.5-11-30PLB(A)	14.5	15.6	21.2	59	0.5-11-59PLB(A)	29	30.1	35.7
31	0.5-11-31PLB(A)	15	16.1	21.7	60	0.5-11-60PLB(A)	29.5	30.6	36.2
32	0.5-11-32PLB(A)	15.5	16.6	22.2					

4	122-0023-001	焊片 Fitting Nail	磷青铜 Phosphor Bronze	2	电镀(锡): 整个表面镀层30u"MIN,再镀锡 80u"MIN..
3	142-0023-001	铆钉 Actuator	LCP(UL94V-0)	1	黑色
2	111-0023-001	端子 Contact	磷青铜 Phosphor Bronze	n×1	电镀(锡): 整个表面镀层30u"MIN,再镀锡 80u"MIN..
1	132-0023-001	基座 Housing	LCP(UL94V-0)	1	本色
序号	料号	名称	材料	数量	备注
未注公差					
X.° ±3° X.X° ±0.5°					
<10	10-30	>30	单位	比例	Design Units
±0.2	±0.25	±0.3	MM Only	—	METRIC
制作	审核	批准	材料	图号	006-0023-001
崔华文	洪新江	Z.DR	见图解	品名	0.5-11-nPLB(A型焊片)
				页码	1 OF 1
				Part No	60023-****-001

适用FPC寸法  
APPLICABLE FPC

旧底图总号

底图总号

签字

日期