

版次	日期	内 容
A1	03.07.08	原始版本
A2	05.06.10	新版本

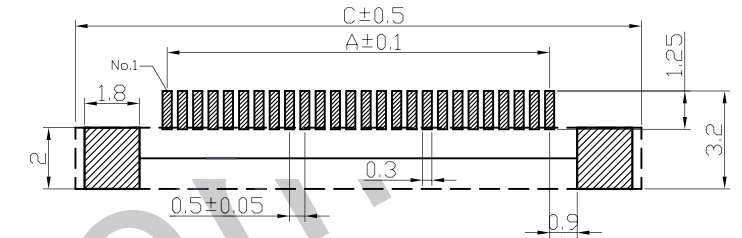
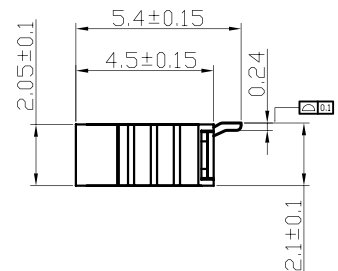
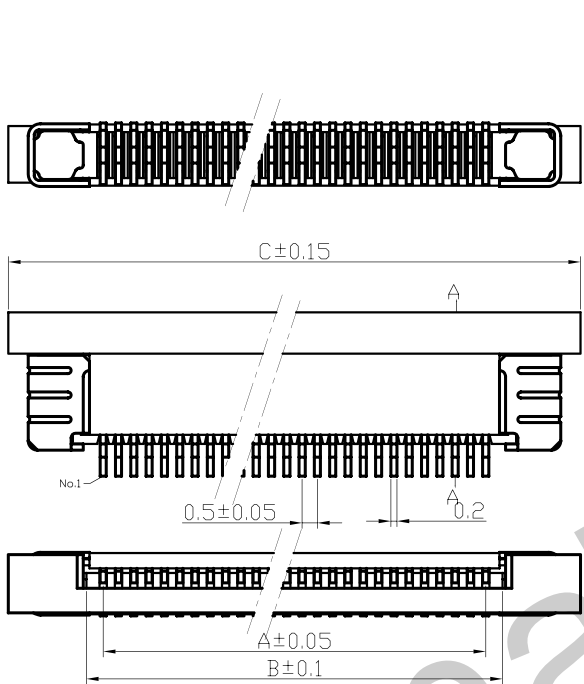

适用线路板

RECOMMENDED PCB LAYOUT

Pin位	Type	A	B	C	Pin位	Type	A	B	C
4	0.5A-4PBS	1.5	2.6	7.7	33	0.5A-33PBS	16	17.1	22.2
5	0.5A-5PBS	2	3.1	8.2	34	0.5A-34PBS	16.5	17.6	22.7
6	0.5A-6PBS	2.5	3.6	8.7	35	0.5A-35PBS	17	18.1	23.2
7	0.5A-7PBS	3	4.1	9.2	36	0.5A-36PBS	17.5	18.6	23.7
8	0.5A-8PBS	3.5	4.6	9.7	37	0.5A-37PBS	18	19.1	24.2
9	0.5A-9PBS	4	5.1	10.2	38	0.5A-38PBS	18.5	19.6	24.7
10	0.5A-10PBS	4.5	5.6	10.7	39	0.5A-39PBS	19	20.1	25.2
11	0.5A-11PBS	5	6.1	11.2	40	0.5A-40PBS	19.5	20.6	25.7
12	0.5A-12PBS	5.5	6.6	11.7	41	0.5A-41PBS	20	21.1	26.2
13	0.5A-13PBS	6	7.1	12.2	42	0.5A-42PBS	20.5	21.6	26.7
14	0.5A-14PBS	6.5	7.6	12.7	43	0.5A-43PBS	21	22.1	27.2
15	0.5A-15PBS	7	8.1	13.2	44	0.5A-44PBS	21.5	22.6	27.7
16	0.5A-16PBS	7.5	8.6	13.7	45	0.5A-45PBS	22	23.1	28.2
17	0.5A-17PBS	8	9.1	14.2	46	0.5A-46PBS	22.5	23.6	28.7
18	0.5A-18PBS	8.5	9.6	14.7	47	0.5A-47PBS	23	24.1	29.2
19	0.5A-19PBS	9	10.1	15.2	48	0.5A-48PBS	23.5	24.6	29.7
20	0.5A-20PBS	9.5	10.6	15.7	49	0.5A-49PBS	24	25.1	30.2
21	0.5A-21PBS	10	11.1	16.2	50	0.5A-50PBS	24.5	25.6	30.7
22	0.5A-22PBS	10.5	11.6	16.7	51	0.5A-51PBS	25	26.1	31.2
23	0.5A-23PBS	11	12.1	17.2	52	0.5A-52PBS	25.5	26.6	31.7
24	0.5A-24PBS	11.5	12.6	17.7	53	0.5A-53PBS	26	27.1	32.2
25	0.5A-25PBS	12	13.1	18.2	54	0.5A-54PBS	26.5	27.6	32.7
26	0.5A-26PBS	12.5	13.6	18.7	55	0.5A-55PBS	27	28.1	33.2
27	0.5A-27PBS	13	14.1	19.2	56	0.5A-56PBS	27.5	28.6	33.7
28	0.5A-28PBS	13.5	14.6	19.7	57	0.5A-57PBS	28	29.1	34.2
29	0.5A-29PBS	14	15.1	20.2	58	0.5A-58PBS	28.5	29.6	34.7
30	0.5A-30PBS	14.5	15.6	20.7	59	0.5A-59PBS	29	30.1	35.2
31	0.5A-31PBS	15	16.1	21.2	60	0.5A-60PBS	29.5	30.6	35.7
32	0.5A-32PBS	15.5	16.6	21.7					

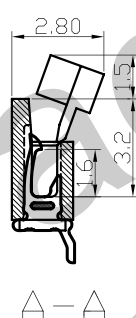

材料
MATERIAL
外壳:尼龙46 UL94V-0 本色
Housing: NYLON46 UL94V-0 Grey
锁扣: PPS UL94V-0 褐色
Loeker: PPS UL94V-0
接触件:磷青铜,表面镀锡合金
Contact:Phosphor bronze, tin/lead-plated
焊片:磷青铜,表面镀锡合金
Solder tab:Phosphor bronze, tin/lead-plated

- 1、塑件表面应光洁、无毛刺、明显收缩、缺陷、裂纹等现象;
- 2、未注公差按SJ1372-79中7级;
- 3、温度范围: -25°C~85°C;
- 4、额定电压: 50V, AC, DC;
- 5、接触电阻: ≤0.03Ω;
- 6、绝缘电阻: ≥500MΩ;
- 7、耐压: 500V, AC/minute.

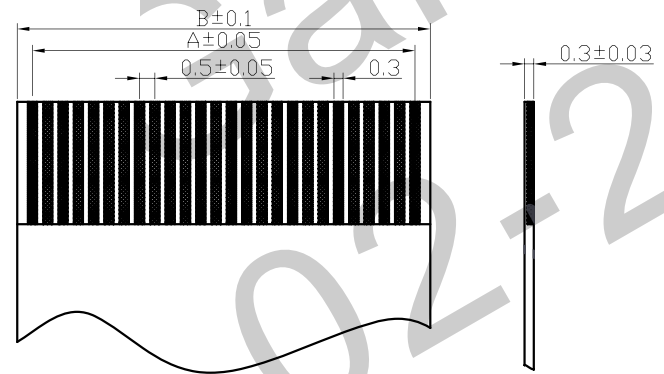

适用FPC寸法
APPLICABLE FPC

组成	材料	
端子	C5210R-EH(磷青铜)	表面附着Ni1um以上, Sn2.5以上
基座	PA46(尼龙) UL94-0 本色	
锁扣	PPS(黑色或棕色)	
制作:	审核:	批准:
洪新江	周 华	

版次	日期	内 容
A	05.06.10	原始版本

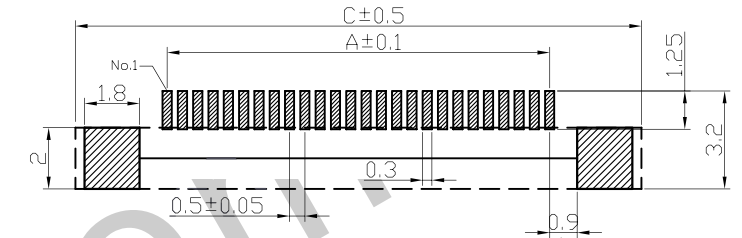
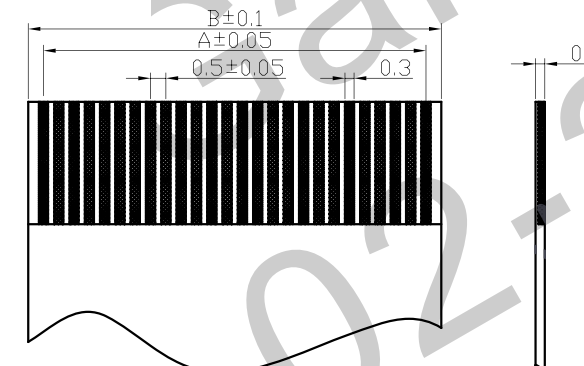
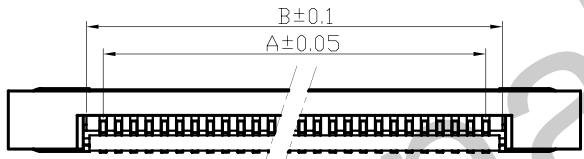
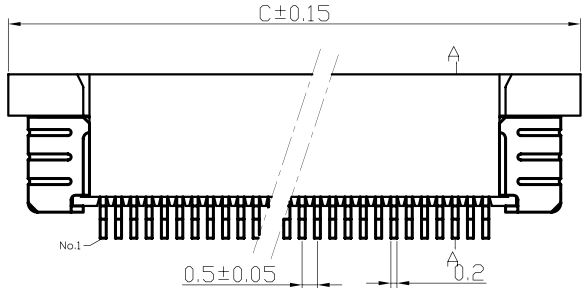
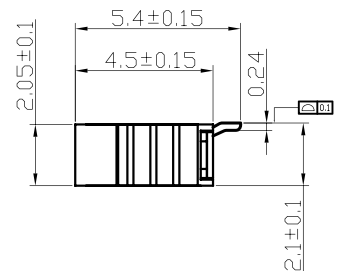
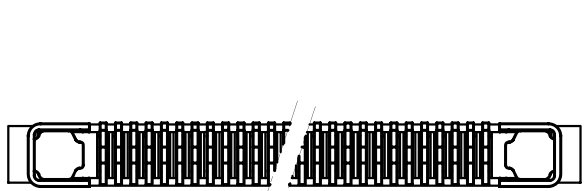

适用线路板

RECOMMENDED PCB LAYOUT

Pin位	Type	A	B	C	Pin位	Type	A	B	C
4	0.5A-4PBX	1.5	2.6	7.7	33	0.5A-33PBX	16	17.1	22.2
5	0.5A-5PBX	2	3.1	8.2	34	0.5A-34PBX	16.5	17.6	22.7
6	0.5A-6PBX	2.5	3.6	8.7	35	0.5A-35PBX	17	18.1	23.2
7	0.5A-7PBX	3	4.1	9.2	36	0.5A-36PBX	17.5	18.6	23.7
8	0.5A-8PBX	3.5	4.6	9.7	37	0.5A-37PBX	18	19.1	24.2
9	0.5A-9PBX	4	5.1	10.2	38	0.5A-38PBX	18.5	19.6	24.7
10	0.5A-10PBX	4.5	5.6	10.7	39	0.5A-39PBX	19	20.1	25.2
11	0.5A-11PBX	5	6.1	11.2	40	0.5A-40PBX	19.5	20.6	25.7
12	0.5A-12PBX	5.5	6.6	11.7	41	0.5A-41PBX	20	21.1	26.2
13	0.5A-13PBX	6	7.1	12.2	42	0.5A-42PBX	20.5	21.6	26.7
14	0.5A-14PBX	6.5	7.6	12.7	43	0.5A-43PBX	21	22.1	27.2
15	0.5A-15PBX	7	8.1	13.2	44	0.5A-44PBX	21.5	22.6	27.7
16	0.5A-16PBX	7.5	8.6	13.7	45	0.5A-45PBX	22	23.1	28.2
17	0.5A-17PBX	8	9.1	14.2	46	0.5A-46PBX	22.5	23.6	28.7
18	0.5A-18PBX	8.5	9.6	14.7	47	0.5A-47PBX	23	24.1	29.2
19	0.5A-19PBX	9	10.1	15.2	48	0.5A-48PBX	23.5	24.6	29.7
20	0.5A-20PBX	9.5	10.6	15.7	49	0.5A-49PBX	24	25.1	30.2
21	0.5A-21PBX	10	11.1	16.2	50	0.5A-50PBX	24.5	25.6	30.7
22	0.5A-22PBX	10.5	11.6	16.7	51	0.5A-51PBX	25	26.1	31.2
23	0.5A-23PBX	11	12.1	17.2	52	0.5A-52PBX	25.5	26.6	31.7
24	0.5A-24PBX	11.5	12.6	17.7	53	0.5A-53PBX	26	27.1	32.2
25	0.5A-25PBX	12	13.1	18.2	54	0.5A-54PBX	26.5	27.6	32.7
26	0.5A-26PBX	12.5	13.6	18.7	55	0.5A-55PBX	27	28.1	33.2
27	0.5A-27PBX	13	14.1	19.2	56	0.5A-56PBX	27.5	28.6	33.7
28	0.5A-28PBX	13.5	14.6	19.7	57	0.5A-57PBX	28	29.1	34.2
29	0.5A-29PBX	14	15.1	20.2	58	0.5A-58PBX	28.5	29.6	34.7
30	0.5A-30PBX	14.5	15.6	20.7	59	0.5A-59PBX	29	30.1	35.2
31	0.5A-31PBX	15	16.1	21.2	60	0.5A-60PBX	29.5	30.6	35.7
32	0.5A-32PBX	15.5	16.6	21.7					

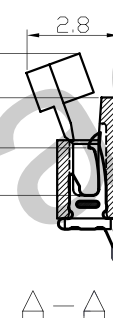

材料
MATERIAL
外壳:尼龙46 UL94V-0 本色
Housing: NYLON46 UL94V-0 Grey
锁扣: PPS UL94V-0 褐色
Locker: PPS UL94V-0
接触件:磷青铜,表面镀锡合金
Contact:Phosphor bronze, tin/lead-plated
焊片:磷青铜,表面镀锡合金
Solder tab:Phosphor bronze, tin/lead-plated

- 1、塑件表面应光洁、无毛刺、明显收缩、缺陷、裂纹等现象;
- 2、未注公差按SJ1372-79中7级;
- 3、温度范围: -25°C~85°C;
- 4、额定电压: 50V, AC, DC;
- 5、接触电阻: ≤0.03Ω;
- 6、绝缘电阻: ≥500MΩ;
- 7、耐压: 500V, AC/minute.

适用FPC寸法
APPLICABLE FPC

组成	材料	
端子	C5210R-EH(磷青铜)	表面附着Ni1um以上, Sn2.5以上
基座	PA46(尼龙) UL94-0 本色	
锁扣	PPS(黑色或棕色)	
制作:	审核:	批准:
洪新江	洪新江	