

更改 REV	修改内容 MODIFICATION
A	ECR00796
B	ECN00918

NOTES :
 1. MATERIAL :
 INSULATOR : HIGH TEMPERATURE
 THERMOPLASTIC , UL94V-0.
 COLOR : IVORY
 CONTACT : PHOSPHOR BRONZE.
 COVER : STAINLESS
 3.PART NO: XDCN-X9-0002

PLATING :
 F CONTACT AREA : Gold Flash Plated OVER Ni
 SOLDER AREA : Tin Plated OVER Ni
 B CONTACT AREA : 10μ" Au Plated OVER Ni
 SOLDER AREA : Tin Plated OVER Ni

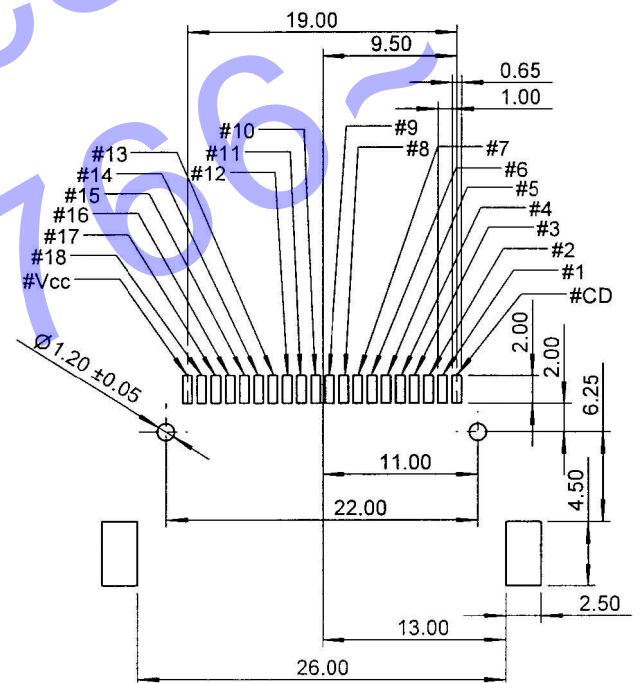
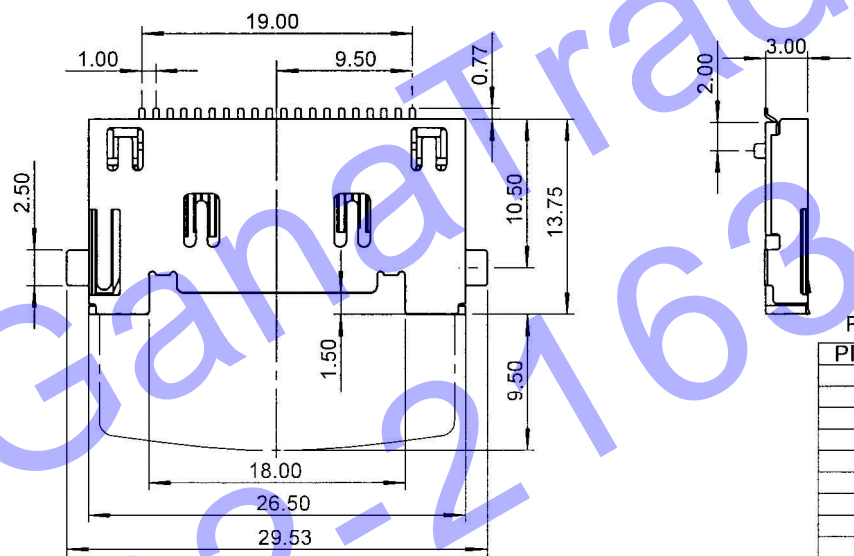
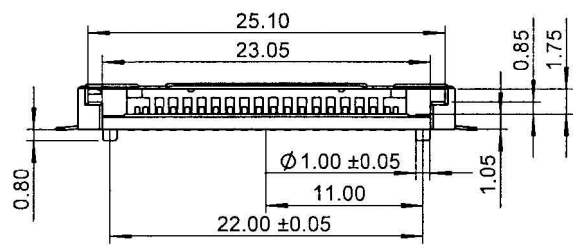
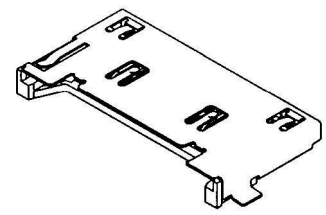

Pin Assignment:

PIN NO:	NAME
#1	GND
#2	R/-B
#3	-RE
#4	-CE
#5	CLE
#6	ALE
#7	-WE
#8	-WP
#9	GND
#10	D0
#11	D1
#12	D2
#13	D3
#14	D4
#15	D5
#16	D6
#17	D7
#18	VCC

GENERAL TOLERANCE		HDC 有限公司	
X ± 0.50	X.° ± 5°	名稱(TITLE)	xD Card Connector
.X ± 0.30	.X° ± 2°		
.XX ± 0.20	.XX° ± 1°	圖號(DWG. NO.)	
	.XXX° ± 0.5°	XDCN-X9-0002-B	
單位(UNIT)	料號(PART NO.)	圖號(DWG. NO.)	
mm	XDCN-X9-0002	XDCN-X9-0002-B	
審核(APROVAL)	核對(CHECKED)	製圖(DRAWN)	比例 SCALE
			2:1
			張數 SHEET
			1 / 1
			角注 修改 REV
			B