

SCHMATIC

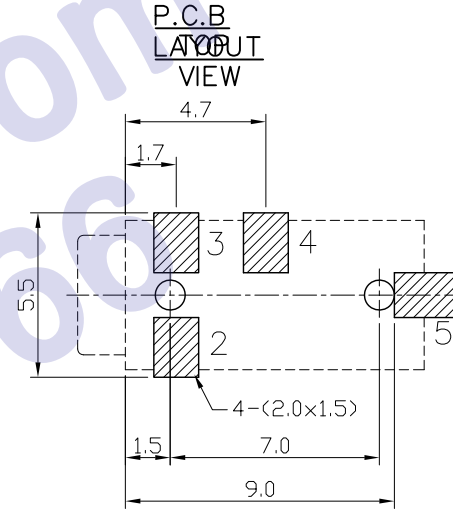
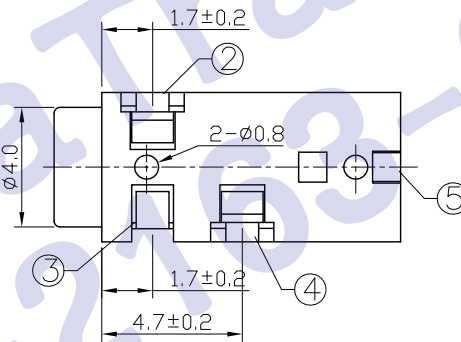
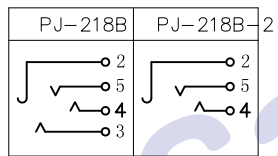

- SPECIFICATION**
1. Rating : DC 30V 0.5A;
 2. Contact resistance: $\leq 0.03\Omega$;
 3. Insulation resistance: $\geq 100M\Omega$ (DC250V);
 4. Withstand voltage: 500VAC ;
 5. Insertion and extraction force: 3-20N;
 6. life test: 5,000 cycles.

5	CONTACT FOOT	1	PHOSPHOR BRONZE	T= Ag
4	SPRING PIECE	1	PHOSPHOR BRONZE	T= Ag
3	CONTACT FOOT	1	PHOSPHOR BRONZE	T= Ag
2	SPRING PIECE	1	PHOSPHOR BRONZE	T= Ag
1	HOUSING	1	PA46	
NO.	DESCRIPTION	QTY	MATERIAL	PLATING

UNIT:MM	TYPE:	MODEL NO:	PAPER NO:	PAGE 1 OF 1
	PHONE JACK	PJ-2018B	TOLERANCE	SCALE
			±0.15	4:1
			±1.5'	VER
				1

DESIGNER		HDC有限公司
BY: CHECK		
BY: APPROVED		
BY:		