

RECOMMENDED P. C. B. LAYOUT  
UNSPECIFIED TOLERANCE: ±0.05  
(BOTTOM VIEW)

REV. LTR.	DESCRIPTION	SIGN	DATE
5	Update drawing	PD X	2011.05.20
6	Update drawing	Kingbo	2012.09.10

Ordering information:  
**PJ30060** - □ **66** □ **0A** □ □ □ **3**  
 (1) (2) (3) (4) (5) (6) (7) (8)

(1):Series No.  
 (2):Schematic option:A B C D E F  
 (3):Material of housing:66=PA66 (Standard)  
 (4):Housing color:0A=Black  
 (5):Terminal plating  
 T=Tin(Sn) plating (Standard)  
 G=Gold(Au) plating  
 (6):Bushing plating:  
 N=Bushing is nickel(Ni) plating  
 G=Bushing is gold(Au) plating  
 (7):Special option:  
 0=No special option  
 1=Without spring  
 2=Without cover  
 3=Without spring and cover  
 (8):Packing mode:  
 3=Plastic box packing

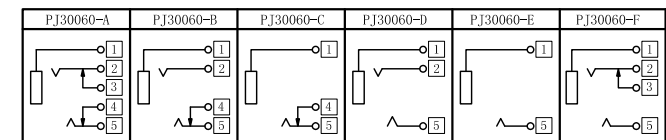
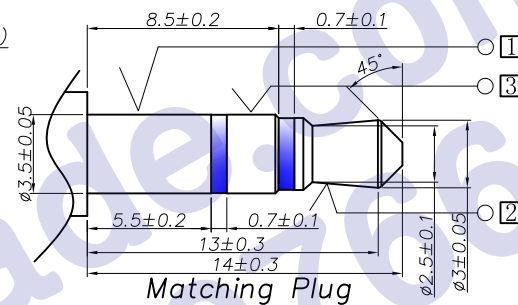

□ TERMINAL NO.

Specification:

- Rating : DC 30V 0.5A.
- Contact resistance: ≤30mΩ.  
After test: ≤50mΩ
- Insulation resistance: ≥100MΩ (500VDC).  
After test: ≥50MΩ
- Withstanding voltage: 500VAC.
- Insertion and extraction force: 3N~30N.
- life test: 5000cycles min.
- Operation temperature range:-20℃~70℃.
- Preservative temperature range:-40℃~85℃.
- Sign"▲"is importance dimension.

9	Bushing	1	Copper alloy	PJ30060-88(ZT-JK0014)	Nickel/gold plating
8	Spring(卡簧)	1	Spring wire	PJ30060-65(TP-JK0013)	Nickel plating
7	Tip spring	5	Phosphor bronze t0.3	PJ30060-05(JA-JK0026)	Tin/gold plating
6	Shunt terminal	4	Brass t0.4	PJ30060-04(JA-JK0025)	Tin/gold plating
5	Shunt terminal	3	Brass t0.4	PJ30060-03(JA-JK0024)	Tin/gold plating
4	Ring spring	2	Phosphor bronze t0.25	PJ30060-02(JA-JK0023)	Tin/gold plating
3	Earth terminal	1	Brass t0.5	PJ30060-01(JA-JK0022)	Tin/gold plating
2	cover	1	PBT	PJ30170-S2(GZ-JK0001)	Black
1	Housing	1	PA66	PJ30060-S1(ST-JK0014)	Black
NO.	DESCRIPTION	QTY	MATERIAL	PART NO.	REMARK

UNIT:MM	TYPE:	MODEL NO:	PAPER NO: A4	PAGE 1 OF 1
	φ3.5 PHONE JACK	PJ30060- 660A _ _ 3	TOLERANCE	ANGLES
			±0.3	±2°
			SCALE	VER
			FULL	9

DESIGNER BY:	Kingbo	2012.09.10
CHECK BY:	Matt	2012.09.10
APPROVED BY:	JGG	2012.09.10

HDC有限公司