

???	??	??	??
REV. LTR.	DESCRIPTION	SIGN	DATE

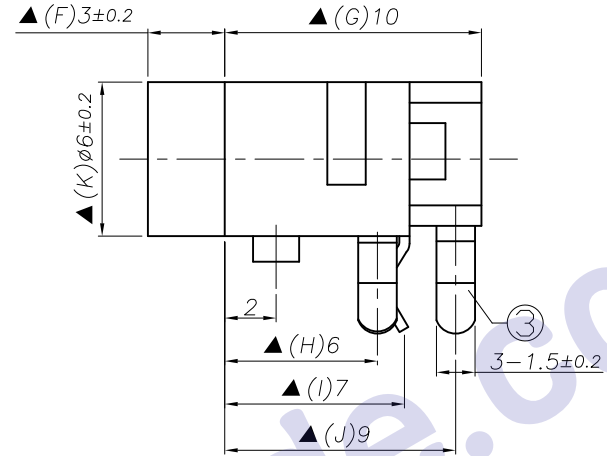

Matching Plug

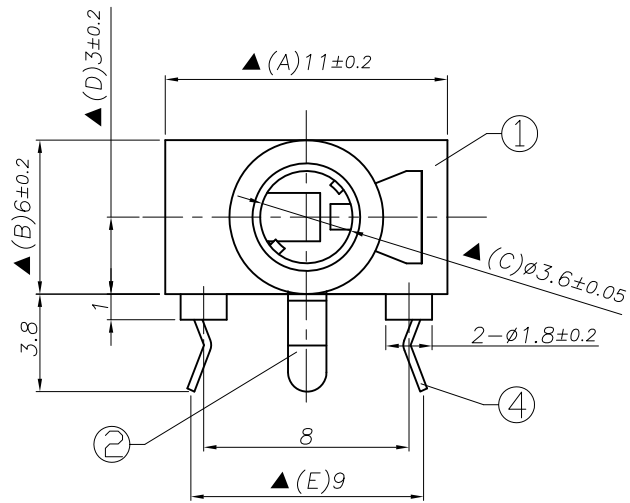
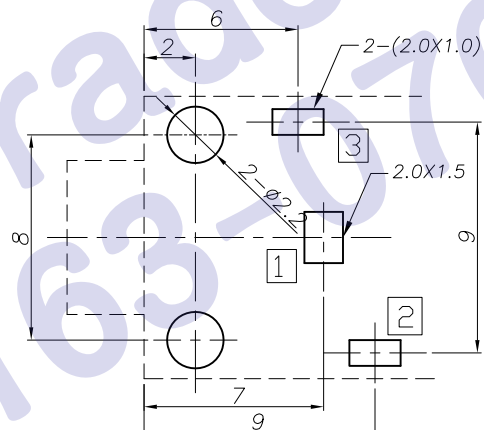
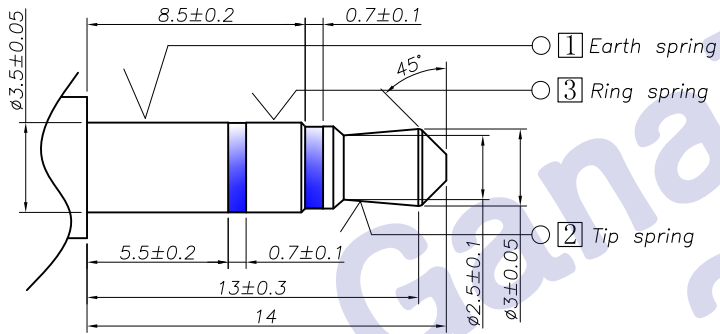

RECOMMENDED P. C. B. LAYOUT
UNSPECIFIED TOLERANCE: ±0.05
(COPPER-SIDED VIEW)

Ordering information:
PJ30080-D PB 0A S 00 4
 (1) (2) (3) (4) (5) (6) (7)
 (1):Series No.
 (2):Schematic option: D
 (3):Material of housing:
 PB=PBT (Standard)
 (4):Housing color:
 Zero 0A=Black (Standard)
 (5):Terminal plating
 S=Silver(Ag) (Standard)
 (6):Special option:
 00=No special option
 (7):Packing mode:
 4=Bag packing

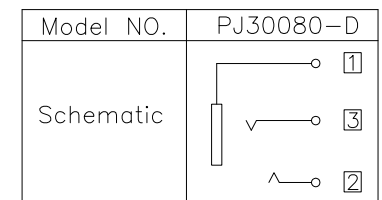

Circuit Diagram Terminal No.

Specification:

- Rating : DC 30V 0.5A.
- Contact resistance: ≤30mΩ.
After test: ≤50mΩ.
- Insulation resistance: ≥100MΩ (500VDC).
After test: ≥50MΩ.
- Withstand voltage: 500VAC.
- Insertion and extraction force: 3N~30N.
- life test: 5000cycles min.
- Operation temperature range: -20°C~70°C.
- Preservative temperature range: -40°C~85°C.
- Sign"▲" is importance dimension.

④	Ring spring	③	1	Phosphor bronze t0.3	PJ30080-03(TP-951)	Silver plating
③	Tip spring	②	1	Phosphor bronze t0.3	PJ30080-02(TP-952)	Silver plating
②	Earth spring	①	1	Phosphor bronze t0.4	PJ30080-01(JA-953)	Silver plating
①	Housing		1	PBT+15%GF,UL 94V-0	PJ30080-S1(ST-950)	Black

NO.	DESCRIPTION	QTY	MATERIAL	PART NO.	REMARK
UNIT: MM		TYPE:		MODEL NO:	
		∅3.5 PHONE JACK		PJ30080-DPBOAS004	
DESIGNER BY:		Bull.pan		2011.04.08	
CHECK BY:					
APPROVED BY:					
		PAPER NO: A4		PAGE 1 OF 1	
		TOLERANCE		ANGLES	
		±0.3		±2°	
		SCALE		VER	
		FULL		1	

HDC有限公司