

REV.	LTR.	DESCRIPTION	SIGN	DATE

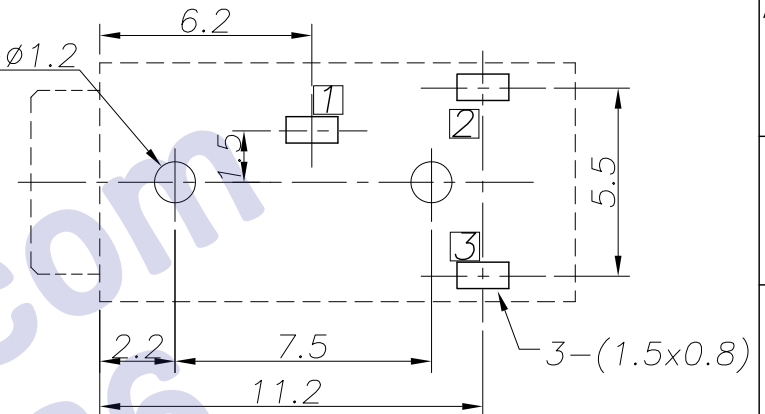
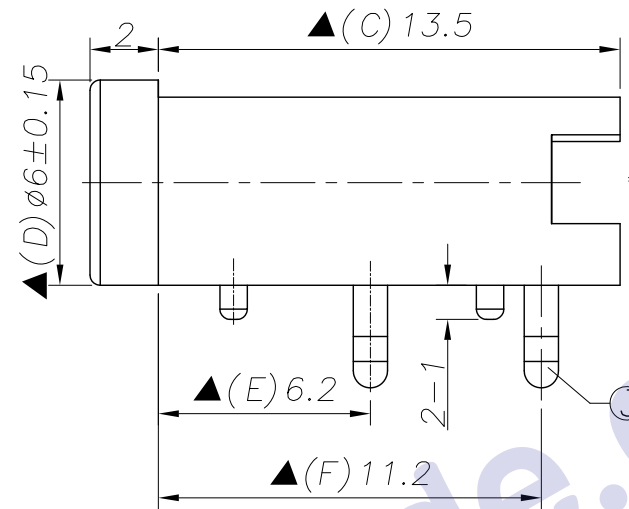
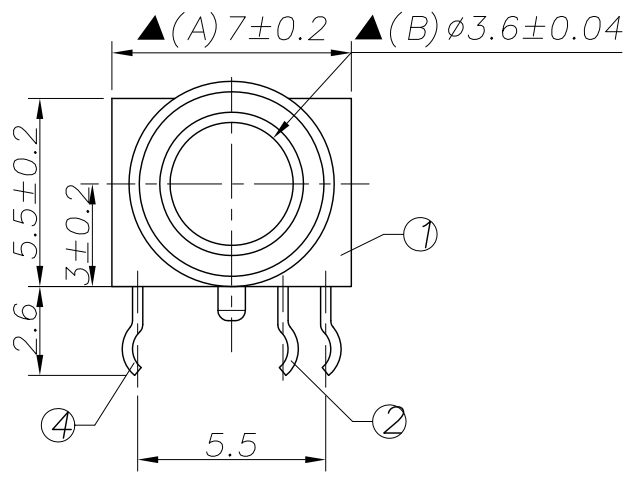

RECOMMENDED P. C. B. LAYOUT
 UNSPECIFIED TOLERANCE: ±0.05
 (BOTTOM VIEW)

- Specification:
- Rating : DC 30V 0.5A.
 - Contact resistance: ≤30mΩ.
After test: ≤50mΩ.
 - Insulation resistance: ≥100MΩ (500VDC).
After test: ≥50MΩ.
 - Withstanding voltage: 500VAC.
 - Insertion and extraction force: 3N~30N.
 - Life test: 5000 cycles min.
 - Operation temperature range: -20°C~70°C.
 - Preservative temperature range: -40°C~85°C.
 - Sign"▲" is importance dimension.

Ordering information:
 P J 3 0 1 2 0 ? ? ? ? T 0 0 ?
 (1) (2) (3) (4) (5) (6) (7)

(1): Series No
 (2): Schematic option: D E
 (3): Material of housing:
 PB=PBT 66=PA66
 (4): Housing color:
 0A=Black
 (5): Terminal plating
 T=Tin(Sn) S=Silver(Ag)
 (6): Special option
 00=No special option
 (7): Packing mode:
 3=Plastic box packing
 4=Bag packing

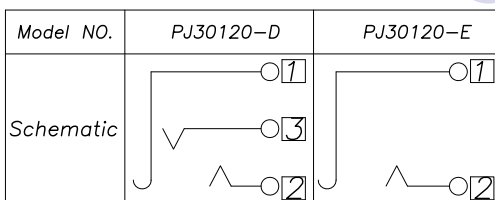
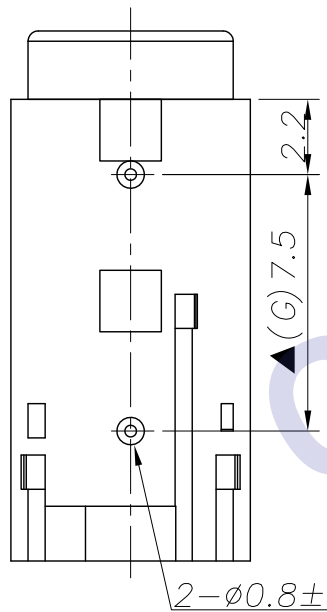

□: TERMINAL NO.

④	Ring spring	3	1	Phosphon bronze t0.3	PJ30120-03	Sn/Silver plating
③	Tip spring	2	1	Phosphon bronze t0.25	PJ30120-02	Sn/Silver plating
②	Earth spring	1	1	Phosphon bronze t0.25	PJ30120-01	Sn/Silver plating
①	Housing	1	1	PBT/PA66	PJ30120-S1	Black

NO	DESCRIPTION	QTY	MATERIAL	PART NO.	REMARK	
UNIT:MM	TYPE:	MODEL NO:		PAPER NO: A4	PAGE 1 OF 1	
	φ3.5 PHONE JACK	PJ30120-	TOLERANCE	ANGLES	SCALE	VER
			±0.3	±2'	N/A	01

DESIGNER BY: jp.K 2011.7.21
 CHECK BY:
 APPROVED BY:

HDC有限公司