

REV. LTR.	DESCRIPTION	SIGN	DATE
	Instead Scheme	CHENBIN	2009.08.21

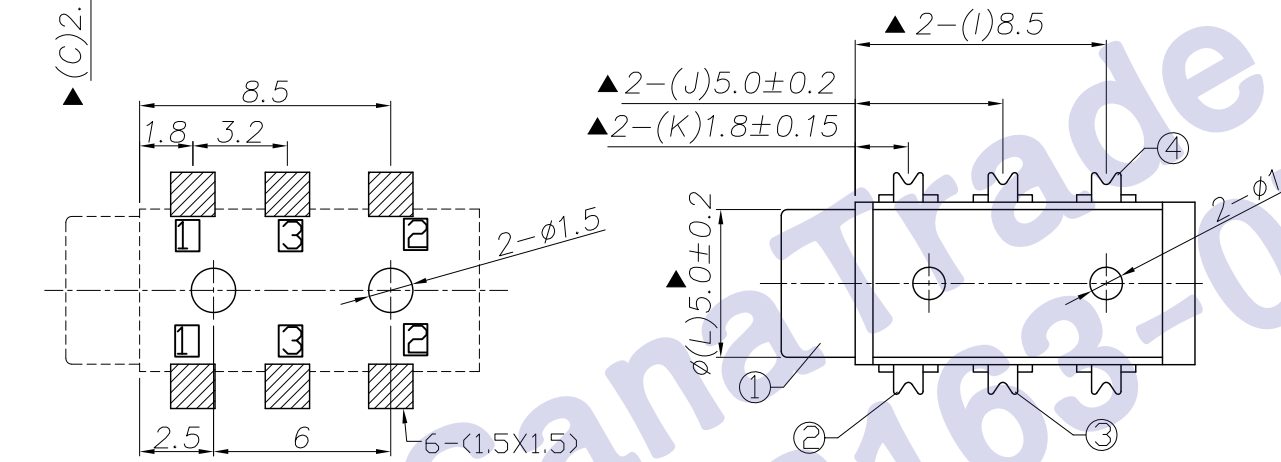

Ordering information:  
PJ3013D D 9T0AS 00 1  
 (1) (2) (3)(4)(5) (6)(7)  
 (1):Series No.  
 (2):Schematic option: D  
 (3):Material of housing: 9T=PA9T  
 (4):Housing color:0A=Black  
 (5):Terminal plating:S=Silver(Ag)  
 (6):Special option:  
 00=No special option  
 (7):Packing mode:  
 1=Reel packing

Specification:  
 1.Rating ?DC 30V 0.5A?  
 2.Contact resistance?≤50m??  
 After test:≤100m?  
 3.Insulation resistance??100M? (250VDC)?  
 After test:?50M?  
 4.Withstand voltage?500VAC ?  
 5.Insertion and extraction force??3N?  
 6.life test?5000cycles min?  
 7.Operation temperature range??-20  
 8.Preservative temperature range??-40  
 Sign"? "is importance dimension?"

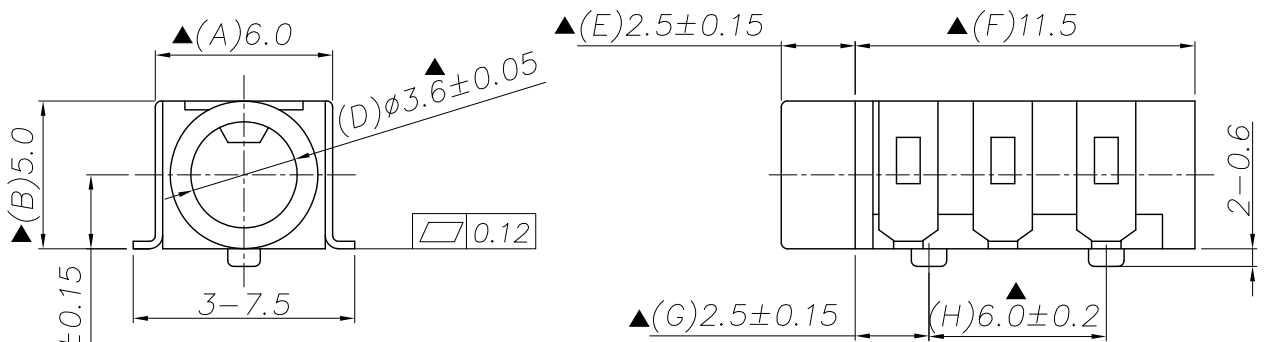
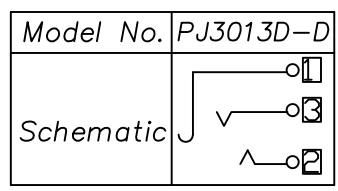
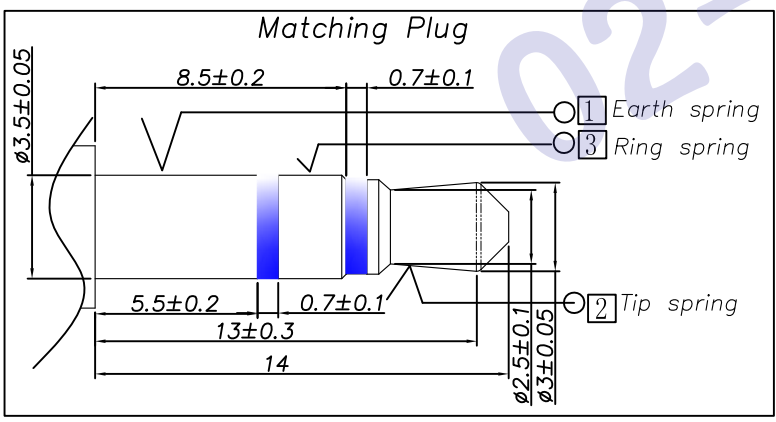

④ Tip spring	2	1	Stainless steel T=0.25	PJ3103D-02(JA-622)	Silver plating
③ Ring spring	3	1	Stainless steel T=0.2	PJ3013D-03(JA-621)	Silver plating
② Earth spring	1	1	Stainless steel T=0.2	PJ3013D-01(JA-621)	Silver plating
① Housing		1	PA9T	PJ3013-S1(ST-JK0031)	Black
NO.	DESCRIPTION	QTY	MATERIAL	PART NO.	REMARK

UNIT:MM	TYPE:	MODEL NO:	PAPER NO: A4	PAGE 1 OF 1
	ø3.5 PHONE JACK	PJ3013D-D9T0AS001	TOLERANCE	ANGLES
			±0.3	±2°
			SCALE	VER
			FULL	4

DESIGNER BY: CHENBIN 2009.8.21  
 CHECK BY:  
 APPROVED BY:  
**HDC有限公司**