

REV. LTR.	DESCRIPTION	SIGN	DATE
	Update drawing	PD X	2011.6.8

Ordering information:

PJ3020F-88 660A? ?? 4

- (1) Series No
- (2) Schematic option: D
- (3) Material of housing: 66=PA66
- (4) Housing color: 0A=Black
- (5) Terminal plating: S=Silver(Ag) T=Tin(Sn)
- (6) Special option: 00=Without bulge 0T=With bulge

(7) Packing mode:  
4=Bag packing

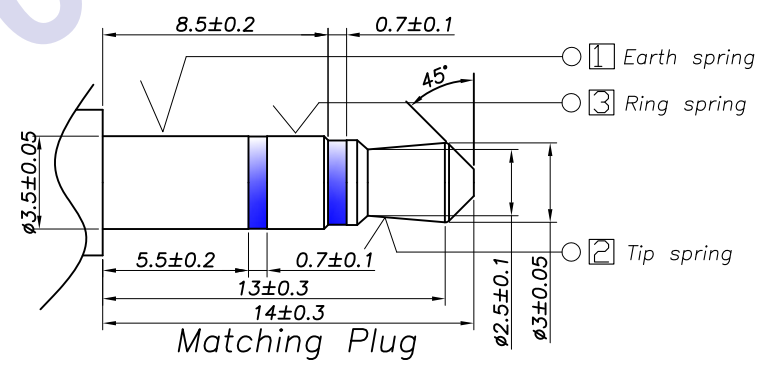

③	Bushing	1	Copper alloy	PJ3020F-88(ZT-916)	Nickel plating		
②	Ring spring	① ② ③	Phosphor bronze t0.25	PJ30200-02(JA-0082)	Silver/Tin plating		
①	Housing	1	PA66	PJ3020F-S1(ST-922)	Black		
NO.	DESCRIPTION	QTY	MATERIAL	PART NO.	REMARK		
UNIT:MM	TYPE:	MODEL NO:		PAPER NO: A4	PAGE 1 OF 1		
	∅3.5 PHONE JACK	PJ3020F-D660AS_ _4		TOLERANCE	ANGLES	SCALE	VER
				±0.3	±2°	FULL	2

DESIGNER BY: PD X 2011.06.08  
CHECK BY:  
APPROVED BY:

HDC有限公司

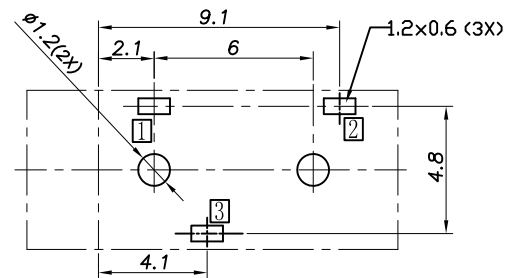
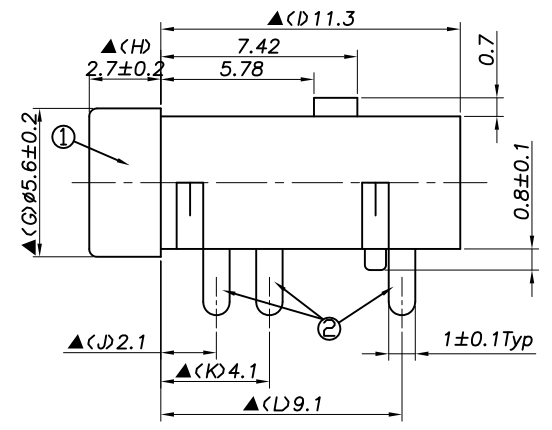
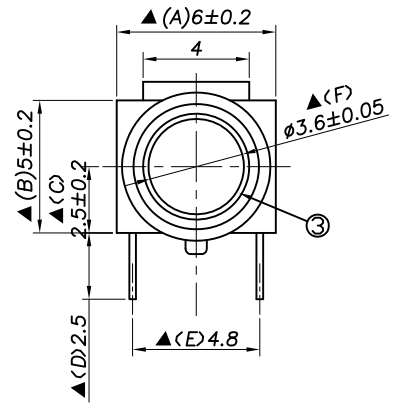

RECOMMENDED P. C. B. LAYOUT  
UNSPECIFIED TOLERANCE: ±0.05  
(BOTTOM VIEW)

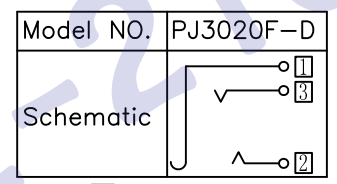
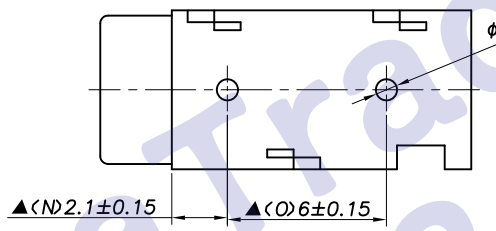

□: TERMINAL NO.

Specification:

- 1.Rating ?DC 30V 0.5A.
- 2.Contact resistance?≤30m?  
After test:≤50m?
- 3.Insulation resistance??100M? (500VDC).  
After test:~50M?
- 4.Withstanding voltage?500VAC.
- 5.Insertion and extraction force?3N
- 6.life test?5000cycles min.
- 7.Operation temperature range?-20
- 8.Preservative temperature range?-40
- 9.Sign"? "is importance dimension.