

REV. LTR.	DESCRIPTION	SIGN	DATE

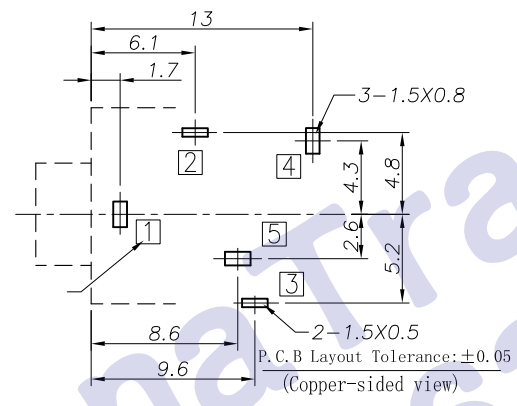

Model No.	PJ30240-A	PA30240-B	PJ30240-C	PJ30240-D	PJ30240-E
Schematic					

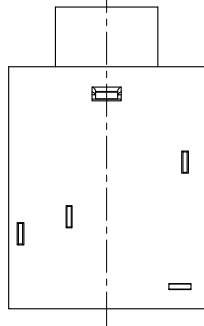
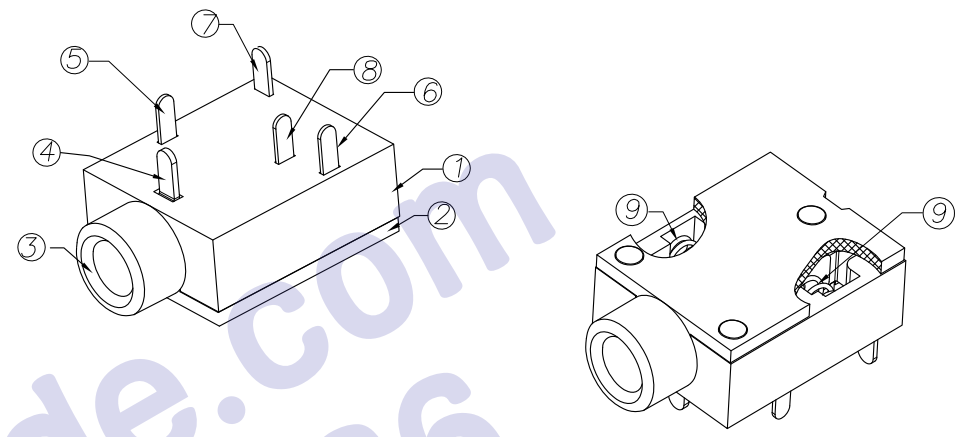
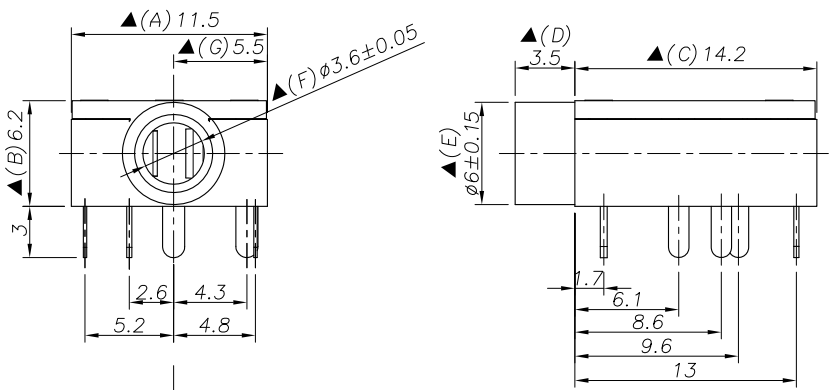
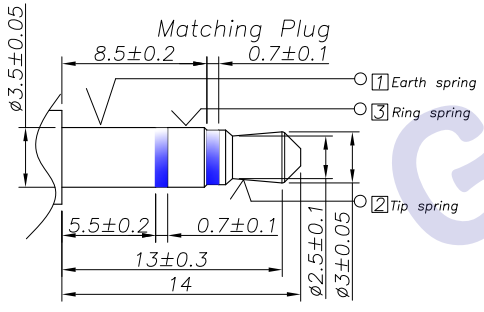

Ordering information:
PJ30240 - ? PB 0A T ?? 3
 ? : Series No.
 ? : Schematic option: A B C D E
 ? : Material of housing:
 PB=PBT (Only)
 ? : Housing color:
 0A=Black (Only)
 ? : Terminal plating
 T=Tin(Sn) (Standard)
 S=Silver(Ag)
 ? : Special option:
 0N=Metal bushing is nickel plating
 0G=Metal bushing is gold plating
 ? : Packing mode:
 3=Plastic box packing
 4=Bag packing

Specification:
 1. Rating : DC 30V 0.5A;
 2. Contact resistance: ≤30mΩ;
 After test: ≤50mΩ
 3. Insulation resistance: ≥100MΩ (500VDC);
 After test: ≥50MΩ
 4. Withstand voltage: 500VAC ;
 5. Insertion and extraction force: 3N~30N;
 6. life test: 5000cycles min;
 7. Operation temperature range: -20℃~70℃
 8. Preservative temperature range: -40℃~85℃
 9. Sign"▲"is importance dimension.

NO.	DESCRIPTION	QTY	MATERIAL	PART NO.	PLATING
⑨	Spring	2	Spring steel		Nickel(Ni) plating
⑧	Shunt terminal-2	5	Brass 0.35t	PJ30240-05	Tin(Sn) plating
⑦	Shunt terminal-1	4	Brass 0.35t	PJ30240-04	Tin(Sn) plating
⑥	Ring spring	3	Phosphor bronze 0.25t	PJ30240-03	Tin(Sn) plating
⑤	Tip spring	1	Phosphor bronze 0.25t	PJ30240-02	Tin(Sn) plating
④	Earth terminal	1	Brass 0.45t	PJ30240-01	Tin(Sn) plating
③	Bushing	1	Copper alloy	PJ30240-88	Nickel(Ni) plating
②	Cover	1	PC	PJ30240-S2	
①	Housing	1	PBT	PJ30240-S1	

UNIT:MM	TYPE:	MODEL NO:	PAPER NO: A4	PAGE 1 OF 1
Standard	PHONE JACK	J30240-PB0AT	TOLERANCE	ANGLES
			±0.3	±2°
			SCALE	VER
			FULL	03

DESIGNER BY: YangGang 2010.11.03
 CHECK BY:
 APPROVED BY:

HDC有限公司