

REV. LTR.	DESCRIPTION	SIGN	DATE
①	Instead Scheme	Bingo	09.02.10

Ordering information:
PJ3027F 9T0AS001
 (1) (2) (3) (4) (5) (6) (7)
 (1):Series No
 (2):Schematic option:S P D
 (3):Material of housing:9T=PA9T
 (4):Housing color:0A=Black
 (5):Terminal plating:S=Silver(Ag)
 (6):Special option:
 00=No special option
 (7):Packing mode:
 1=Reel packing

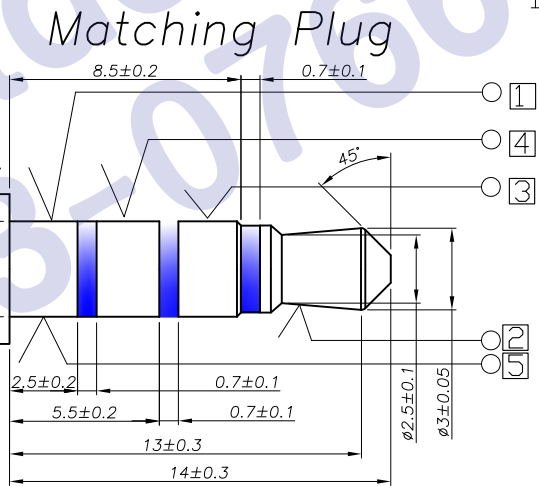
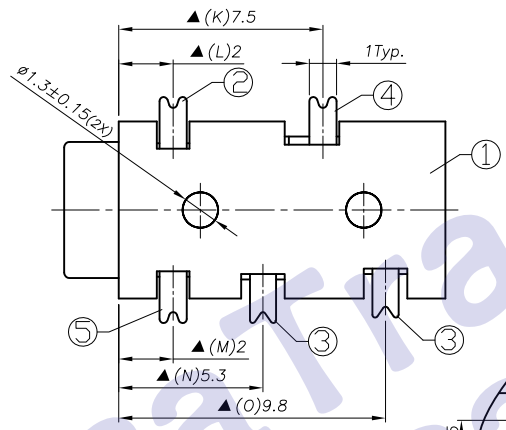
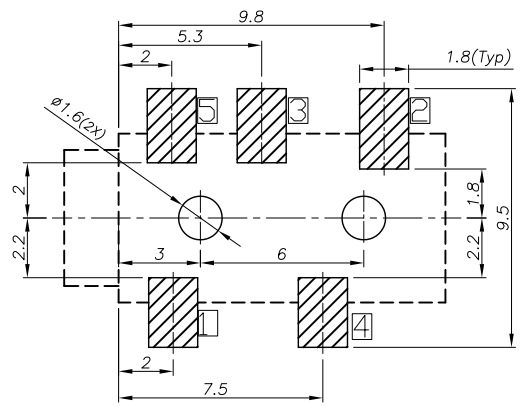
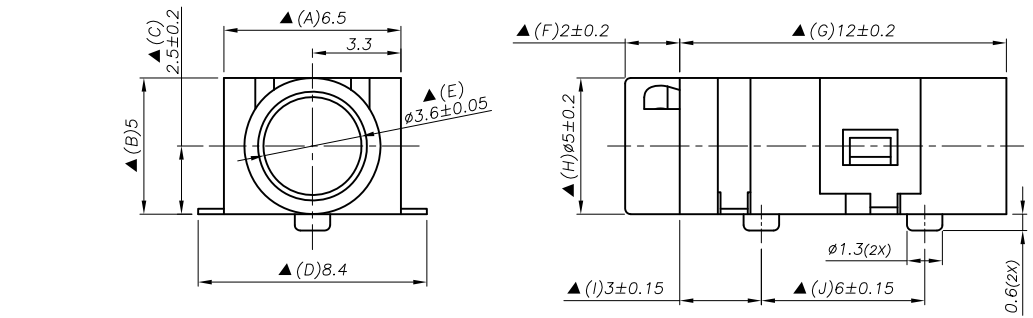

RECOMMENDED P. C. B. LAYOUT
 UNSPECIFIED TOLERANCE: ±0.05
 (COPPER-SIDED VIEW)

Model No.	PJ3027F-S	PJ3027F-P	PJ3027F-D
Schematic			

- Specification:
- Rating ?DC 30V 0.5A?
 - Contact resistance?≤50m??
After test:≤100m?
 - Insulation resistance??100M? (500VDC)?
After test:~50M?
 - Withstanding voltage?500VAC ?
 - Insertion and extraction force??3N?
 - life test?5000cycles min?
 - Operation temperature range? -20~70?
 - Preservative temperature range? -40~85?
 - Sign"? "is importance dimension

NO.	DESCRIPTION	QTY	MATERIAL	PART NO.	REMARK
⑤	Ring spring	5	Phosphor bronze t0.2	PJ3027E-01(TP-996)	Silver plating
④	Ring spring	4	Stainless steel t0.25	PJ3027F-04(TP-1063)	Silver plating
③	Tip spring	2	Phosphor bronze t0.2	PJ3027C-01(JA-648)	Silver plating
②	Earth spring	1	Phosphor bronze t0.2	PJ3027F-01(TP-1062)	Silver plating
①	Housing	1	PA9T, UL 94V-0	PJ3027F-SI(共用ST-1061)	Black

UNIT:MM	TYPE:	MODEL NO:	PAPER NO: A4	PAGE 1 OF 1
	φ3.5 PHONE JACK	PJ3027F- 9T0AS001	TOLERANCE ANGLES	SCALE VER
			±0.3 ±2°	FULL 3

DESIGNER BY: PD X 2011.04.28
 CHECK BY:
 APPROVED BY:

HDC有限公司