

REV. LTR.	DESCRIPTION	SIGN	DATE

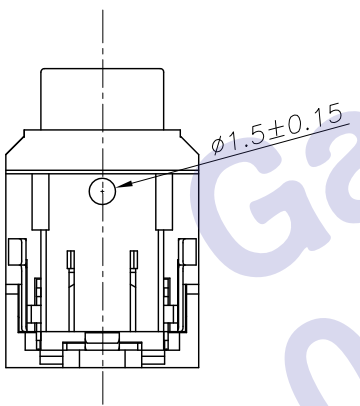
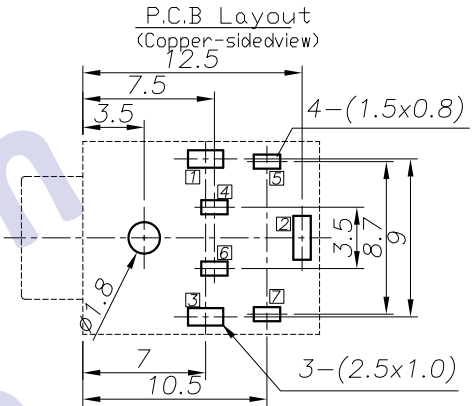
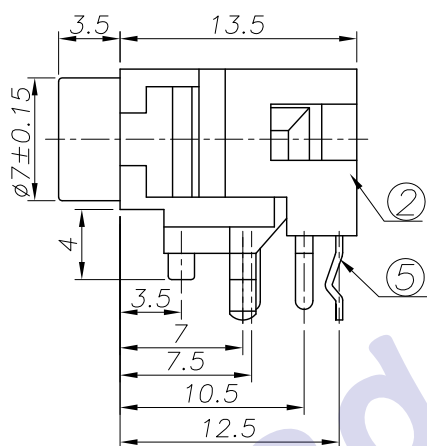
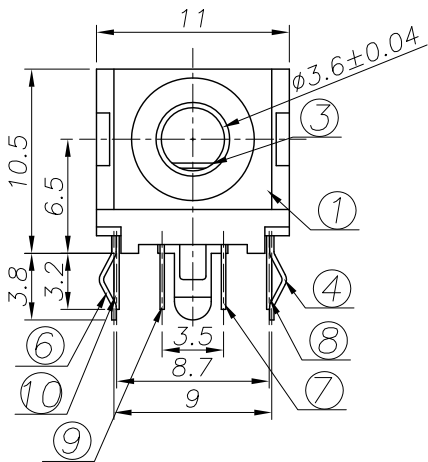

Model No.	PJ30350-B	PJ30350-D	PJ30350-K	PJ30350-W
Schematic				

Ordering information:
 PJ30350- ? PB 0A S 00 4
 (1) (2) (3) (4) (5) (6) (7)
 (1): Series No.
 (2): Schematic option: B D K
 (3): Material of housing:
 PB=PBT (Only)
 (4): Housing color:
 0A=Black (Standard)
 2_=Red
 3_=Orange
 4_=Yellow
 (5): Terminal plating
 6=Silver (Ag) (Standard)
 T=White
 (6): Special option
 No Special option
 (7): Packing mode:
 4: Bag packing

NO.	DESCRIPTION	QTY	MATERIAL	PLATING
10	Break terminal-2	1	Brass	Ag-Plating
9	Transfer terminal-2	1	Phosphor bronze	Ag-Plating
8	Break terminal-1	1	Brass	Ag-Plating
7	Transfer terminal-1	1	Phosphor bronze	Ag-Plating
6	Ring spring	1	Phosphor bronze	Ag-Plating
5	Tip spring	1	Phosphor bronze	Ag-Plating
4	Earth terminal	1	Phosphor bronze	Ag-Plating
3	Dielectric	1	POM	
2	Cover	1	POM	
1	Housing	1	PBT	

SPECIFICATION
 1. Rating ? DC 30V 0.5A?
 2. Contact resistance? ≤30mΩ?
 3. Insulation resistance?? 100MΩ (DC250V)
 4. Withstand voltage? 500VAC ?
 5. Insertion and extraction force? 3-30N;
 6. life test? 5,000 cycles?

UNIT:MM	TYPE:	MODEL NO:	PAPER NO:	PAGE 1 OF 1
	φ3.5 PHONE JACK	PJ30350-__PBOAS004	A4 TOLERANCE ANGLES SCALE VER	
			±0.3 ±2'	1:1 2

DESIGNER: Zhuhong 2008/11/11
 CHECK: _____
 APPROVED: _____
 BY: _____

HDC有限公司