

REV. LTR.	DESCRIPTION	SIGN	DATE
△	Part No. changed	Michae	2008.08.19
△	Transfer terminal material: SUS301 change to phosphor bronze	Michae	2008.11.15
△	Add gold plating	Bull.pan	2011.03.21

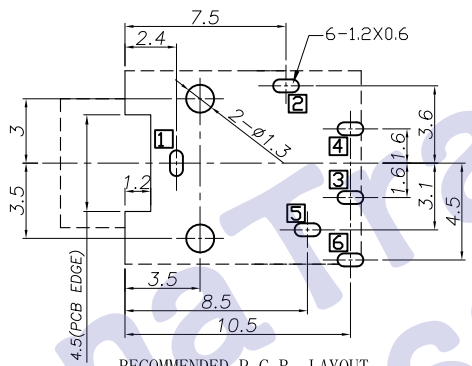

RECOMMENDED P. C. B. LAYOUT
UNSPECIFIED TOLERANCE: ± 0.05
(COPPER-SIDED VIEW)

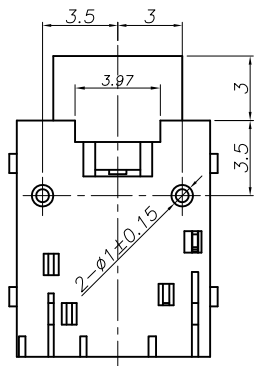
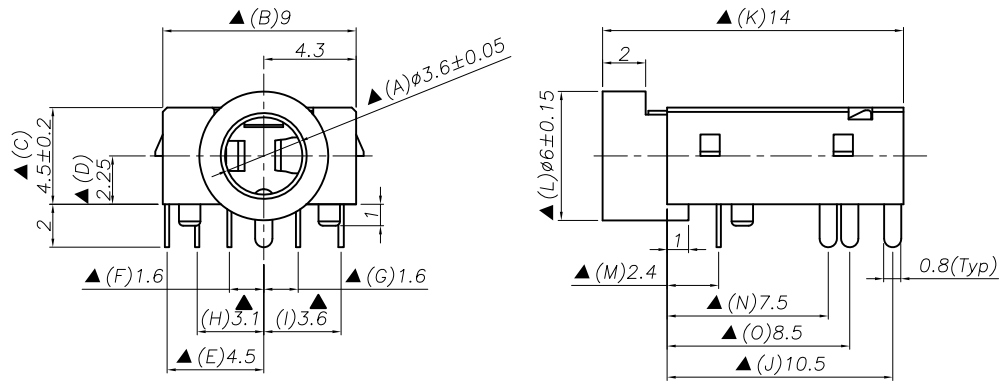
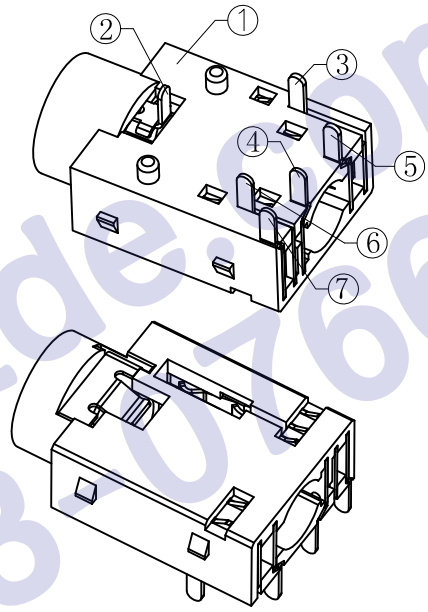

- Ordering information:
PJ30530 - □ □ □ □ □ 00 □
(1) (2) (3) (4) (5) (6) (7)
- (1): Series No.
 - (2): Schematic option: R, K
 - (3): Material of housing:
9T=PA9T PB=PBT
 - (4): Housing color:
0A=Black 2L=Red (0405=PA9T)
5G=Green (0406=PA9T)
6A=Blue (0469=PA9T)
2A=Red (0384=PBT)
5P=Green (0386=PBT)
6C=Blue (0385=PBT)
 - (5): Terminal plating:
S=Silver (Ag)
G=Gold (Au)
 - (6): Special option:
00=No special option
 - (7): Packing mode:
1=Tape reel packing
3=Plastic box packing
4=Bag packing

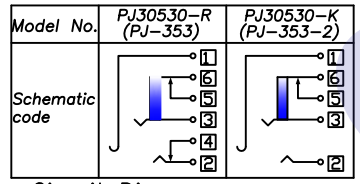

Circuit Diagram □: Terminal No.

- Specification:
- Rating: DC 30V 0.5A.
 - Contact resistance: $\leq 50m\Omega$.
After test: $\leq 100m\Omega$.
 - Insulation resistance: $\geq 100M\Omega$ (500VDC).
After test: $\geq 50M\Omega$.
 - Withstand voltage: 500VAC.
 - Insertion and extraction force: 3N~30N.
 - Life test: 5000cycles min.
 - Operation temperature range: $-20^{\circ}C \sim 70^{\circ}C$.
 - Preservative temperature range: $-40^{\circ}C \sim 85^{\circ}C$.
 - Sign "▲" is importance dimension.

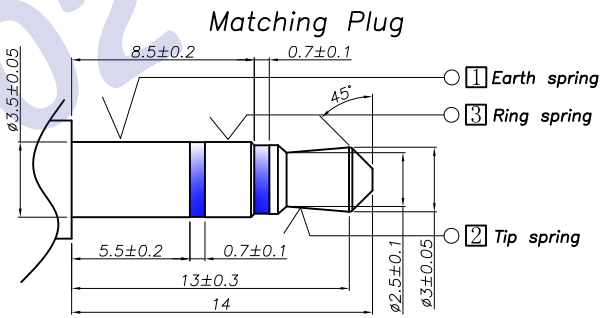

7	Transfer terminal	6	1	Phosphor bronze	0.2t	PJ30530-06	Silver/Gold plating
6	Break terminal	5	1	Brass	0.2t	PJ30530-05	Silver/Gold plating
5	Shunt terminal	4	1	Brass	0.25t	PJ30430-04	Silver/Gold plating
4	Ring spring	3	1	Stainless steel	0.2t	PJ30430-03	Silver/Gold plating
3	Tip spring	2	1	Phosphor bronze	0.25t	PJ30430-02	Silver/Gold plating
2	Earth spring	1	1	Phosphor bronze	0.2t	PJ30430-01	Silver/Gold plating
1	Housing		1	PA9T+33%GF/PBT+15%GF+H	94V-0	PJ30430-S1	
NO.	DESCRIPTION	QTY	MATERIAL	PART NO.	REMARK		
UNIT:MM	TYPE:	MODEL NO:	PAPER NO: A4	PAGE 1 OF 1			
	$\phi 3.5$ PHONE JACK	PJ30530-_-_-_-	TOLERANCE	ANGLES	SCALE	VER	
			± 0.3	$\pm 2^{\circ}$	FULL	4	

DESIGNER BY: Bull.pan 2011.03.21
CHECK BY:
APPROVED BY:

HDC有限公司