

REV. LTR.	DESCRIPTION	SIGN	DATE

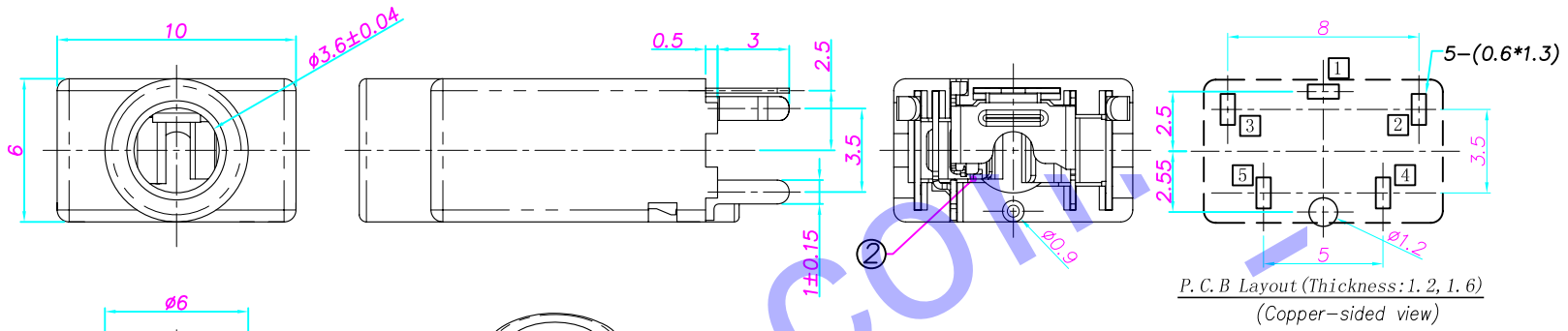
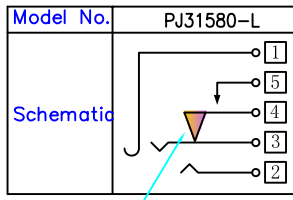

Ordering information:
PJ31580 - L □□ □□ □ □□ □

(1) (2) (3) (4) (5) (6) (7)

- (1): Series No.
- (2): Schematic option: L
- (3): Material of housing:
PB=PBT(Standard)
- (4): Housing color:
0A=Black 2_=Red 3_=Orange
Zero 4_=Yellow 5_=Green 6_=Blue
- (5): Terminal plating
S=Silver(Ag)(Standard)
T=Tin(Sn)
- (6): Special option:
00=No special option
- (7): Packing mode:
3=Plastic box packing

- Specification:
1. Rating : DC 30V 0.5A;
 2. Contact resistance: $\leq 50m\Omega$;
After life test: $\leq 100m\Omega$
 3. Insulation resistance: $\geq 100M\Omega$ (500VDC);
After life test: $\geq 50M\Omega$
 4. Withstand voltage: 500VAC ;
 5. Insertion and extraction force: 3N~30N;
 6. life test: 5000cycles min;
 7. Operation temperature range: -20°C~70°C
 8. Preservative temperature range: -25°C~80°C

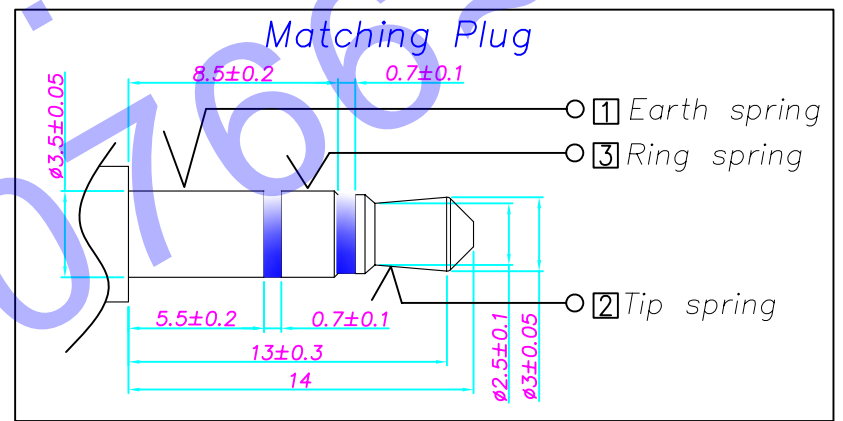
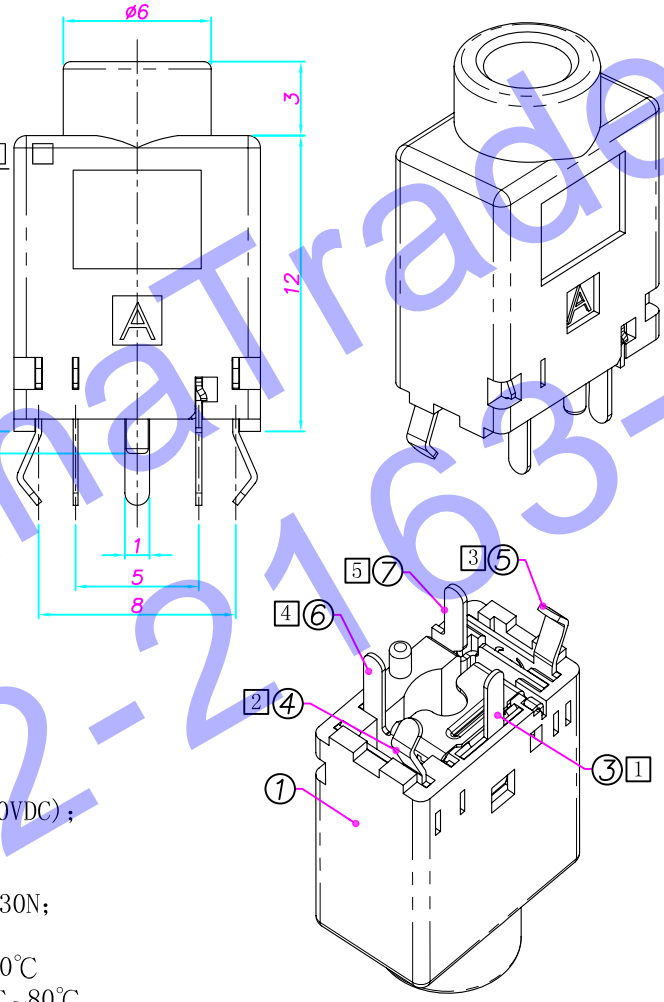

⑦ Break spring	⑤	1	Phosphor bronze 0.25t	PJ31580-05	Silver(Ag) Plating	
⑥ Transfer spring	④	1	Phosphor bronze 0.2t	PJ31580-04	Silver(Ag) Plating	
⑤ Ring spring	③	1	Phosphor bronze 0.25t	PJ31580-03	Silver(Ag) Plating	
④ Tip spring	②	1	Phosphor bronze 0.25t	PJ31580-02	Silver(Ag) Plating	
③ Earth spring	①	1	Stainless steel 0.2t	PJ30580-01(JA-990)	Silver(Ag) Plating	
② Insulator		1	POM,UL94HB	PJ31080-S4	Black	
① Housing		1	PBT,UL-94V-0	PJ31580-S1		
ITEM	DESCRIPTION	QTY	MATERIAL	PART NO.	PLATING & COLOR	
UNIT: MM	TYPE:	MODEL NO:	PAPER NO: A4 PAGE 1 OF 1			
	ø3.5 PHONE JACK (180° Dip type)	PJ31580-LPB_ _ S003	TOLERANCE	ANGLES	SCALE	VER
DESIGNER BY:	YUJUN 2008.5.03		±0.25	±2'	FULL	0
CHECK BY:	H D C 有限公司					
APPROVED BY:						