

更改 REV	设计内容 MODIFICATION	日期 DATE	制图 DRAW	核准 APPROVE
A	图面发行	2011/8/29	JDL	Oscar

**NOTES:**

**ELECTRICAL:**

- VOLTAGE RATING : 125 VAC RMS.
- CURRENT RATING : 1.5 AMP.
- CONTACT RESISTANCE : 50 MILLIOHMS MAX.
- INSULATION RESISTANCE: 500 MEGOHMS MIN @ 500 VDC.
- DIELECTRIC STRENGTH : 1000 VAC RMS 50Hz, 1MIN.

**MECHANICAL:**

- HOUSING MATERIAL : GLASS FILLED POLYESTER UL94V-0
- CONTACT MATERIAL : PHOSPHOR BRONZE  $\phi 0.46\text{mm}$ .
- PLATING : GOLD PLATING OVER NICKEL.
- SHIELD : COPPER ALLOY(OR STEEL ALLOY) 0.20mm THICKNESS PLATING NI.
- OPERATING LIFE : 750 CYCLES MIN.
- PCB RETENTION PRE-SOLDER : 1 LB MIN.
- PCB RETENTION POST-SOLDER: 10 LBS MIN.

**ENVIRONMENTAL:**

- STORAGE :  $-40^{\circ}\text{C}$  TO  $+85^{\circ}\text{C}$ .
- OPERATION:  $-40^{\circ}\text{C}$  TO  $+85^{\circ}\text{C}$ .
- WAVE SOLDERING TEMPERATURE:  $255^{\circ}\sim 265^{\circ}$  (5~10SECONDS).
- ROHS COMPLIANT

MATES WITH MODULAR PLUG CONFORMING TO  
FCC PART 68, SUBPART F.

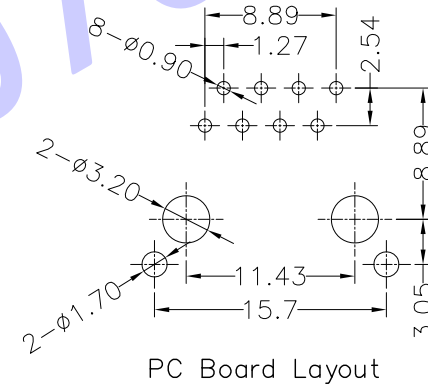
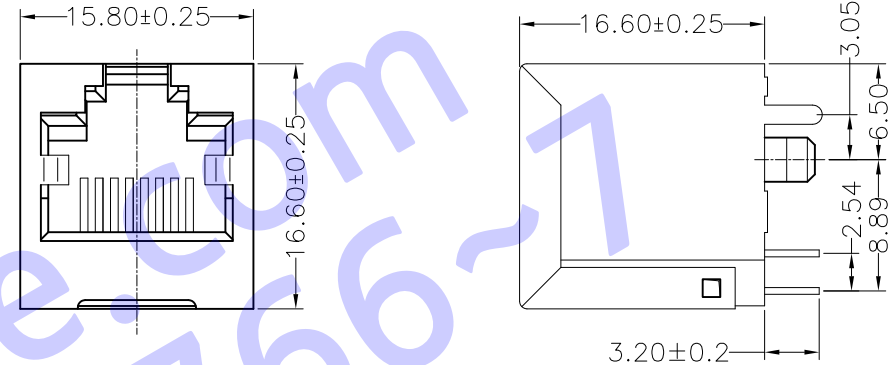

PC Board Layout

PART NUMBER: 5224-031881022X

**52 SERIES:**

Product Style:

- 24-普通型 W=15.00mm, H=15.80mm;
- 4B-大小脚 W=15.68mm, H=16.35mm;
- 4C-扁脚 W=14.70mm, H=13.10mm;
- 4G-4P SMT 型;
- 4F-分拆脚 脚距W&H=16.75mm;
- 4L-板脚 W/LED;

Transformer feature:

- 0-不装 1-HRJ-001 2-HRJ-002

TYPE SHIELD

- 1-W/O SHIELD; 2-HALF SHIELD;
- 3-FULL SHIELD

PORTS (插口) 1-1X1 4-1X4 8-1X8

POSITIONS: 4-4P 6-6P 8-8P 0-10P

CONTACTS 4-4C 6-6C 8-8C

PEG/TAB (固定脚)

- 0-W/O PEG; 1-FRONT PEG 3.05
- 2-FRONT PEG 3.68; 3-FRONT PEG 4.57;
- 4-BACK PEG 3.05

GOLD PLATING

- 1-FU"; 2-1.5U"; 3-3U";
- 4-6U"; 5-15U"; 6-30U";
- 7-50U"

LOGO 标识

- 0-W/O LOGO
- 1-W/HAXN
- 2-W/HAXN W/UL

PLASTIC MATERIAL & COLOR OPTION

- 1-PBT BLACK
- 2-PA46 BLACK

LED STYLE & COLOR

- 0-W/O LED
- 1-L LED GREEN,R LED YELLOW
- 2-L LED YELLOW,R LED GREEN
- 3-L LED GREEN,R LED GREEN

◎ : Inspection Item ◎ : Cp/Cpk and SPC Control Item	DIMENSION IN mm [Inch]		HDC 有限公司	
	TOLERANCE UNLESS OTHERWISE SPECIFIED		专案号 FILE NO.	图号 DWG NO.
	.X± 0.20	.X° ± 1°	5224-8P-002	
	.XX± 0.15	.X° ± 0.5°	名称 TITLE 5224 180度 1X1 JACK(脚前3.05mm)	
.XXX± 0.075		核准 APPROVE	审核 CHECK	制图 DRAW
		JDL	Oscar	角法 PROJ.  原数 SHEET 1 / 2
		比例 SCALE 1:1	图幅 SIZE A3	更改 REV A