

1 2 3 4 5 6 7 8

更改 REV	设计内容 MODIFICATION	日期 DATE	制图 DRAW	核准 APPROVE
A	图面发行	2011/8/29	JDL	Oscar

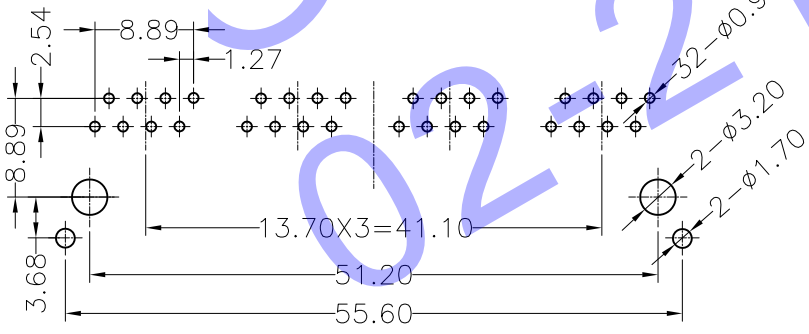
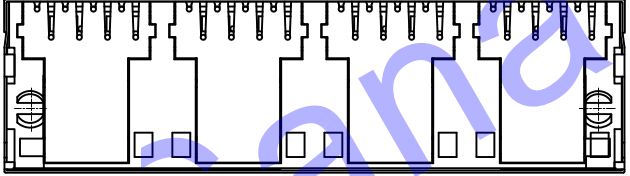
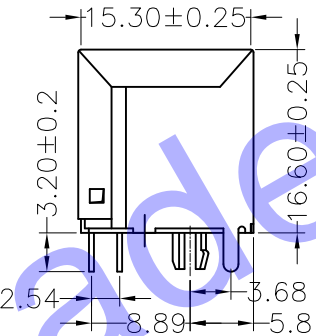
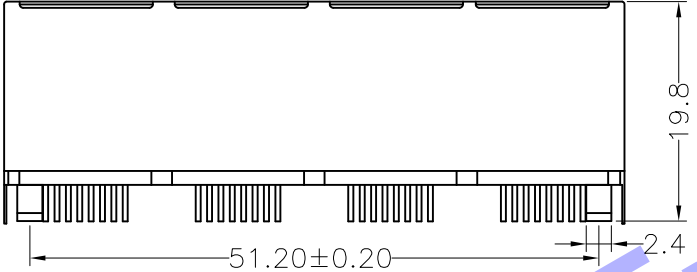
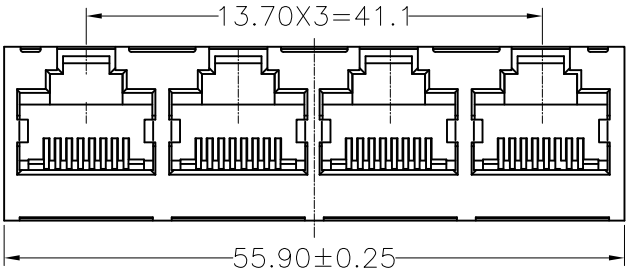

NOTES:

ELECTRICAL:

- 1. VOLTAGE RATING : 125 VAC RMS.
- 2. CURRENT RATING : 1.5 AMP.
- 3. CONTACT RESISTANCE : 50 MILLIOHMS MAX.
- 4. INSULATION RESISTANCE: 500 MEGOHMS MIN @ 500 VDC.
- 5. DIELECTRIC STRENGTH : 1000 VAC RMS 50Hz, 1MIN.

MECHANICAL:

- 1. HOUSING MATERIAL : GLASS FILLED POLYESTER UL94V-0
- 2. CONTACT MATERIAL : PHOSPHOR BRONZE ø0.46mm.
- 3. PLATING : GOLD PLATING OVER NICKEL.
- 4. SHIELD : COPPER ALLOY(OR STEEL ALLOY) 0.20mm THICKNESS PLATING NI.
- 5. OPERATING LIFE : 750 CYCLES MIN.
- 6. PCB RETENTION PRE-SOLDER : 1 LB MIN.
- 7. PCB RETENTION POST-SOLDER: 10 LBS MIN.

ENVIRONMENTAL:

- 1. STORAGE : -40°C TO +85°C.
- 2. OPERATION : -40°C TO +85°C.
- 3. WAVE SOLDERING TEMPERATURE: 255°~265° (5~10SECONDS).
- 4. ROHS COMPLIANT

MATES WITH MODULAR PLUG CONFORMING TO FCC PART 68, SUBPART F.

PART NUMBER: 5224-034882021X

52 SERIES:

Product Style:

- 24-插脚 W=15.00mm, H=15.80mm;
- 4B-大插脚 W=15.68mm, H=16.35mm;
- 4C-插脚 W=14.70mm, H=13.10mm;
- 4G-4P SMT 插;
- 4F-分脚 插 W&H=16.75mm;
- 4L-插脚 W/LED;
- Transformer feature:
- 0-不装 1-HRJ-001 2-HRJ-002
- TYPE SHIELD
- 1-W/O SHIELD; 2-HALF SHIELD;
- 3-FULL SHIELD
- PORTS 插的 1-1X1 4-1X4 8-1X8
- POSITIONS: 4-4P 6-6P 8-8P 0-10P
- CONTACTS 4-4C 6-6C 8-8C
- PEG/TAB (插脚插)
- 0-W/O PEG; 1-FRONT PEG 3.05
- 2-FRONT PEG 3.68; 3-FRONT PEG 4.57;
- 4-BACK PEG 3.05

GOLD PLATING

- 1-FU"; 2-1.5U"; 3-3U";
- 4-6U"; 5-15U"; 6-30U";
- 7-50U"

LOGO 标

- 0-W/O LOGO
- 1-W/HAXN
- 2-W/HAXN W/UL

PLASTIC MATERIAL & COLOR OPTION

- 1-PBT BLACK
- 2-PA46 BLACK

LED STYLE & COLOR

- 0-W/O LED
- 1-L LED GREEN,R LED YELLOW
- 2-L LED YELLOW,R LED GREEN
- 3-L LED GREEN,R LED GREEN

◎◎ : Inspection Item ◎P : Cp/Cpk and SPC Control Item ◎PK : Control Item	DIMENSION IN mm [Inch]		HDC有限公司	
	TOLERANCE UNLESS OTHERWISE SPECIFIED		专案号 FILE NO.	图号 DWG NO. 5224-8P-005
	.XX± 0.20	X.°± 1°	名称 TITLE 5224 180度 1X4 JACK(脚前3.68)	
	.XX± 0.15	.X°± 0.5°		
.XXX± 0.075		核准 APPROVE	审核 CHECK	制图 DRAW Oscar
		角法 PROJ.	图例 SCALE 1:1	图框 SHEET A3
		比例 SCALE 1:1	图框 SIZE A3	更改 REV A

F

E

D

C

B

A

1 2 3 4 5 6 7 8