

NOTES:

MATERIAL:

- 1.HOUSING MATERIAL :GLASS FILLED POLYESTER(UL94V-0).
- 2.CONTACT MATERIAL :PHOSPHOR BRONZE $\phi 0.46\text{mm}$ (C5100).
- 3.PLATING :GOLD PLATING OVER NICKEL.
- 4.SHIELD: COPPER ALLOY 0.20mm THICKNESS PLATING NI.

ELECTRICAL:

- 1.VOLTAGE RATING :125 VAC RMS.
- 2.CURRENT RATING :1.5 AMP.
- 3.CONTACT RESISTANCE :50 MILLIOHMS MAX.
- 4.INSULATION RESISTANCE :500 MEGOHMS MIN @ 500V DC.
- 5.DIELECTRIC WITHSTANDING RESISTANCE :1000V AC RMS 50Hz. 1MIN.

MECHANICAL:

- 1.DURRABILITY :750 CYCLES MIN.
- 2.PCB RETENTION PRE-SOLDER :1 LB MIN.

ENVIRONMENTAL:

- 1.STORAGE : -40°C TO $+85^{\circ}\text{C}$.
2. OPERATION : 0°C TO 70°C .

MATES WITH MODULAR PLUG CONFORMING TO FCC PART 68,SUBPART F.

PART NUMBER:

B 99-03108201XX3X

99 SERIES
PCB JACK

(99系列PCB接口)

SHIELD (屏蔽壳):

- 1-W/O SHIELD (非屏)
 - 2-HALF SHIELD (半包)
 - 3-FULL SHIELD (全包)
- PORTS (插口):
- 1-1X1 (一口) . 2-1X2 (二口)
 - 4-1X4 (四口) . 5-1X5 (五口)
 - 6-1X6 (六口) . 8-1X8 (八口)

POSITIONS (金针位置):

- 4-4POSITIONS (4P)
- 6-6POSITIONS (6P)
- 8-8POSITIONS (8P)
- 0-10POSITIONS (10P)

CONTACTS (金针根数):

- 1-2. 3. 4. 7PIN. 2-2CONTACTS (2C)
- 4-4CONTACTS (4C) . 6-6CONTACTS (6C)
- 8-8CONTACTS (8C) . 0-10CONTACTS (10C)

PEG/TAB (边定位铁脚):

- 0-W/O PEG (无铁脚) . 1-FRONT PEG 3.05 (前脚3.05)
- 2-FRONT PEG3.68 (前脚3.68) . 3-FRONT PEG4.57 (前脚4.57)
- 4-BACK PEG3.05 (后脚3.05)

GOLD PLATING
(镀金厚度)

- 1-F U". 2-1.5U"
- 3-3U". 4-6U"
- 5-15U". 6-30U"
- 7-50U"

LOGO (标识):

- 0-W/O LOGO (无标识)
 - 1-W/ HAXN (有HAXN标识)
 - 2-W/ UL (有UL标识)
 - 3-W/ HAXN. UL (有HAXN. UL)
- COLOR (颜色): 1-BLACK (黑色) .
- 2-WHITE (白色) . 3-GRAY (灰色)
 - 4-IVORY (象牙色) . 5-YELLOE (黄色)
 - 6-RED (红色) . 7-GREEN (绿色)

PLASTIC (塑料):

- 1-PBT. 2-NYLON66 (尼龙66) .
- 3-NYLON46 (尼龙46) . 4-ABS

EMI (弹片): 1-W/O EMI (无弹片) .

- 2-W/ EMI (带弹片)

BACK PEG (后背铁脚):

- 0-W/O BACK PEG (无后背铁脚) .
- 1-1BACK PEG (1个后背铁脚)
- 2-2BACK PEG (2个后背铁脚) .
- 3-3BACK PEG (3个后背铁脚)

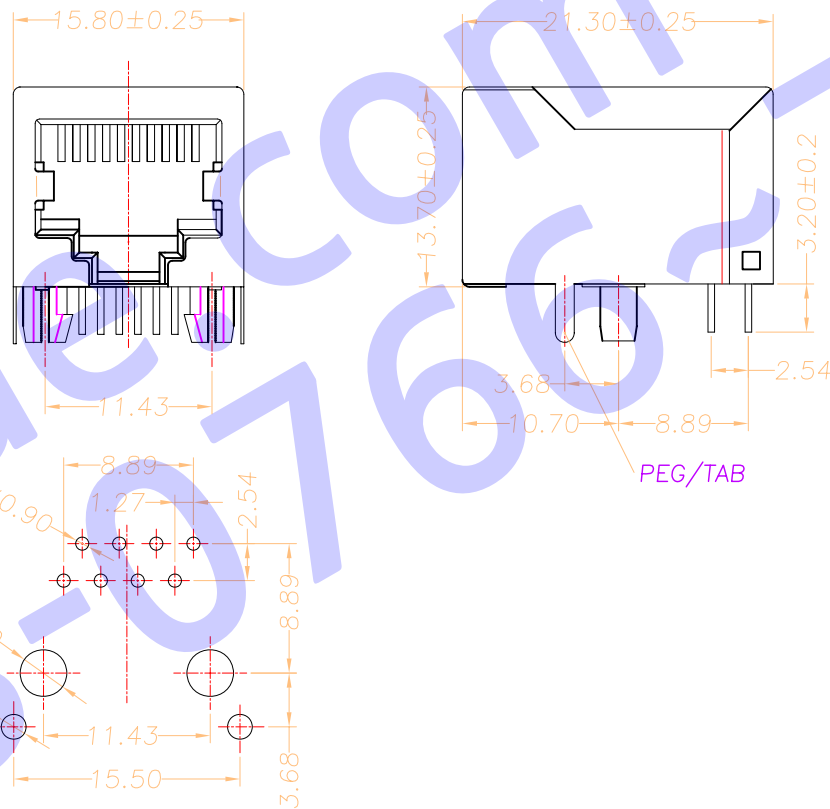

PC Board Layout

<p>MM (INCH)</p> <p>← 公差栏 →</p>		设计 peilei 日期 05.03.05		
<p>MM</p> <p>.0 ± 0.20</p> <p>.00 ± 0.15</p> <p>.000 ± 0.075</p>		审核 GANBO 日期 05.03.06	系列 99	名称 9903-10P8C-SB-1X1
<p>角度 ± 0.01°</p>		批准 xushiyong 日期 05.03.06	图号 B ED-HX-99-10P-008	版本 B
<p>第三角视图</p>		材料:	料号: 请查看注释	共 X 页 第 Y 页
<p>表面处理:</p>		数量:	比例: 1:1	不按比例

DETACHED LISTS