

更改 REV	设计内容 MODIFICATION	日期 DATE	制图 DRAW	批准 APPROVE
A	图面发行	2012/10/29	JDL	Oscar

NOTES:

ELECTRICAL:

1. VOLTAGE RATING : 125 VAC RMS.
2. CURRENT RATING : 1.5 AMP.
3. CONTACT RESISTANCE : 50 MILLIOHMS MAX.
4. INSULATION RESISTANCE: 500 MEGOHMS MIN @ 500 VDC.
5. DIELECTRIC STRENGTH : 1000 VAC RMS 50Hz, 1MIN.

MECHANICAL:

1. HOUSING MATERIAL : NYLON+30%.G.F UL94V-0.
2. CONTACT MATERIAL : PHOSPHOR BRONZE ϕ 0.46mm.
3. PLATING : GOLD PLATING OVER NICKEL.
4. SHIELD, COPPER ALLOY(OR STEEL ALLOY) 0.20mm THICKNESS PLATING NI.
5. LED:OPTION
6. OPERATING LIFE : 750 CYCLES MIN.
7. PCB RETENTION PRE-SOLDER : 1 LB MIN.
8. PCB RETENTION POST-SOLDER: 10 LBS MIN.

ENVIRONMENTAL:

1. STORAGE : -40°C TO +85°C.
2. OPERATION: 0°C TO +70°C.
3. WAVE SOLDERING TEMPERATURE: 255~265° (5~10SECONDS).
4. ROHS COMPLIANT

MATES WITH MODULAR PLUG CONFORMING TO FCC PART 68, SUBPART F.

PART NUMBER: 59A-S1108C-XX

GOLD PLATING U"
1-Fu" 2-2u" 3-3u" 4-6u"

PLASTIC MATERIAL&COLOR:Black/Yellow/Gray
1-PBT+20%GF Black
2-PA46 Black

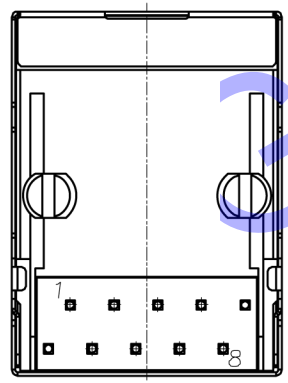
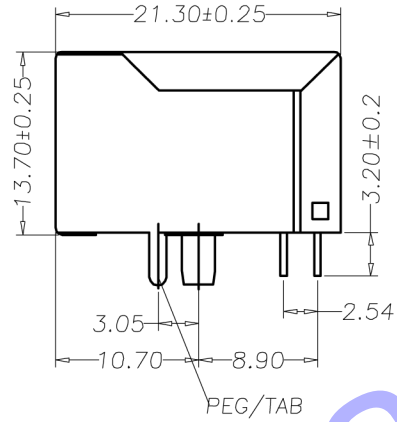
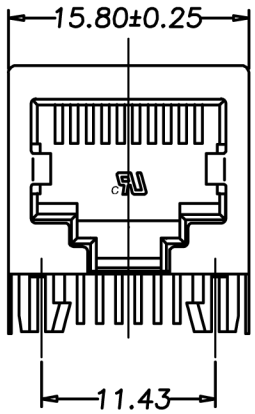

PC Board Layout

◎◎ : Inspection Item ◎CPK : Cp/Cpk and SPC Control Item	DIMENSION IN mm [Inch]		HDC电子有限公司	
	TOLERANCE UNLESS OTHERWISE SPECIFIED		文件号 FILE NO.	图号 DWG NO. YL59A-S1108C
	.X±0.20	X.*±1°	名称 TITLE 59A 1X1 8P8C PCB JACK WITH SHIELDED SIDE ENTRY,ROUND PIN	
	.XX±0.15	.X.*±0.5°		
.XXX±0.075		制图 DRAW Oscar	审核 PROJ. SCALE 1:1	图幅 SIZE A3
批准 APPROVE	检查 CHECK	张数 SHEET 1	页次 REV A	共 1