

更改 REV	设计内容 MODIFICATION	日期 DATE	制图 DRAW	核准 APPROVE
A	图面发行	2012/10/29	JDL	Oscar

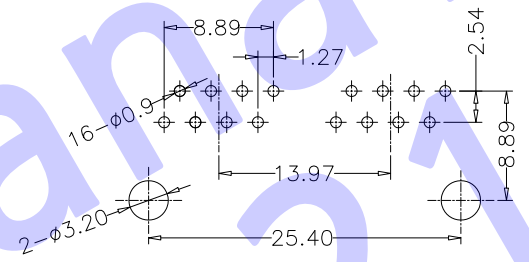
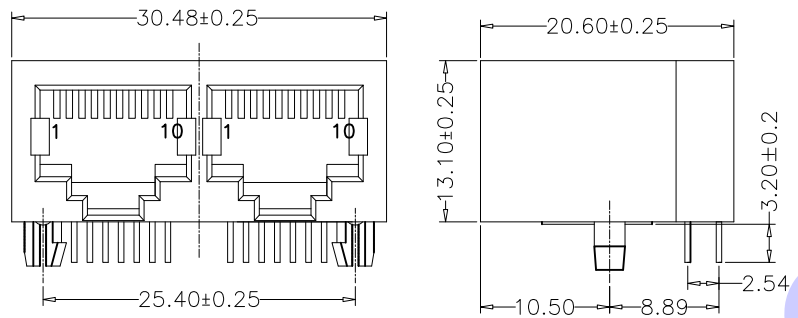

PC Board Layout

NOTES:

ELECTRICAL:

- VOLTAGE RATING : 125 VAC RMS.
- CURRENT RATING : 1.5 AMP.
- CONTACT RESISTANCE : 50 MILLIOHMS MAX.
- INSULATION RESISTANCE: 500 MEGOHMS MIN @ 500 VDC.
- DIELECTRIC STRENGTH : 1000 VAC RMS 50Hz, 1MIN.

MECHANICAL:

- HOUSING MATERIAL : NYLON+30%.G.F UL94V-0.
- CONTACT MATERIAL : PHOSPHOR BRONZE φ0.46mm
- PLATING : GOLD PLATING OVER NICKEL.
- OPERATING LIFE : 750 CYCLES MIN.
- PCB RETENTION PRE-SOLDER : 1 LB MIN.
- PCB RETENTION POST-SOLDER: 10 LBS MIN.

ENVIRONMENTAL:

- STORAGE : -40°C TO +85°C.
- OPERATION: 0°C TO +70°C.
- WAVE SOLDERING TEMPERATURE: 255°~265° (5~10SECONDS).
- ROHS COMPLIANT

MATES WITH MODULAR PLUG CONFORMING TO FCC PART 68, SUBPART F.

PART NUMBER: 9903-112080022X

99SERIES (PCB JACK)	GOLD PLATING U"
产品规格	1-Fu" 2-2u" 3-3u" 4-6u"
03- 普通型	5-15" 6-30u" 7-50u"
SHIELD STYPE	LOGO TYPE:
1-W/O Shield 不包镀 2-Half Shield 半包镀	0-不敷
3-不包镀 4-开上包镀 5-包 包取次包 6-上 包 包取次包	1-W
7-上 包 包取次包 8-上 包 包取次包 9-上 包 包取次包	2-W
PIN STYPE	PLASTIC MATERIAL&COLOR:
1-脚 2-脚	1-PBT+20%GF Black
PORTS	2-PA46 Black
1-1X1 PORT 2-1X2 PORTS	LED Stype:
4-1X4 PORTS 5-1X5 PORTS	0-W/O LED
6-1X6 PORTS 8-1X8 PORTS	1-L Led:Green R Led:Yellow
POSITION	2-L Led:Yellow R Led:Green
0-10POSITION	3-L Led:Green&Orange R Led:Yellow
CONTACTS:	4-L Led:Green&Red R Led:Yellow
4-4CONTACTS 8-8CONTACTS	5-L Led:Green&Yellow R Led:Yellow
0-10CONTACTS	6-L Led:Red R Led:Green
	PEG/TAB&BACK PEG (包壳材料&包壳材料)
	0-W/O PEG 1-脚3.05 无包壳材料 2-脚3.68 无包壳材料
	3-脚4.57 无包壳材料 4-脚3.05 无包壳材料 5-脚3.68 无包壳材料
	6-脚4.57 无包壳材料

◎ : Inspection Item ◎ : Cp/Cpk and SPC Control Item ◎ : APPROVE ◎ : CHECK	DIMENSION IN mm [Inch]		HDC 有限公司	
	TOLERANCE UNLESS OTHERWISE SPECIFIED		专案号 FILE NO.	图号 DWG NO. 9903-10P-022
	.X± 0.20	X°± 1°	名称 TITLE 99 1X2 10P8C JACK (不包括)	
	.XX± 0.15	.X°± 0.5°		
	.XXX± 0.075		制图 DRAW Oscar	角法 PROJ.
核准 APPROVE	审核 CHECK	比例 SCALE 1:1	图框 SIZE A3	更改 REV A