

更改 REV	设计内容 MODIFICATION	日期 DATE	制图 DRAW	核准 APPROVE
A	图纸发行	2012/10/29	JDL	Oscar

NOTES:

**ELECTRICAL:**

- VOLTAGE RATING : 125 VAC RMS.
- CURRENT RATING : 1.5 AMP.
- CONTACT RESISTANCE : 50 MILLIOHMS MAX.
- INSULATION RESISTANCE: 500 MEGOHMS MIN @ 500 VDC.
- DIELECTRIC STRENGTH : 500 VAC RMS 50Hz, 1MIN.

**MECHANICAL:**

- HOUSING MATERIAL : NYLON(PA46)+30%G.F UL94V-0.
- CONTACT MATERIAL : PHOSPHOR BRONZE T=0.35mm (C5210).
- PLATING : GOLD-PLATED IN THE CONTACT AREA
- SHIELD: COPPER ALLOY(OR STEEL ALLOY) 0.20mm THICKNESS
- OPERATING LIFE : 750 CYCLES MIN.
- PCB RETENTION PRE-SOLDER : 1 LB MIN.
- PCB RETENTION POST-SOLDER: 10 LBS MIN.

**ENVIRONMENTAL:**

- STORAGE : -40°C TO +85°C.
- OPERATION: 0°C TO +70°C.
- IR REFLOW PEAK SOLDERING TEMPERATURE:255°C~265°C 5~10 SECONDS.
- ROHS COMPLIANT
- FCC PART 68, SUBPART F.
- MATES WITH MODULAR PLUG CONFORMING TO

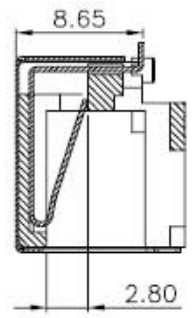
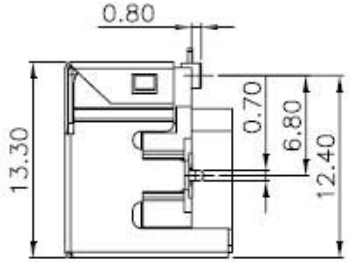
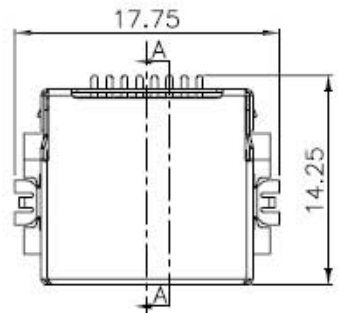

SECTION A-A

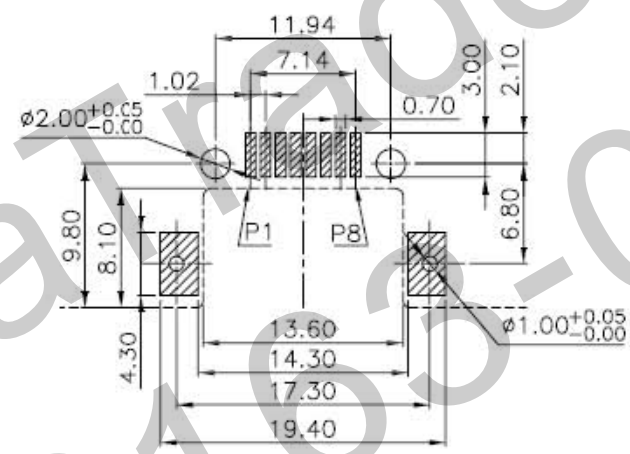
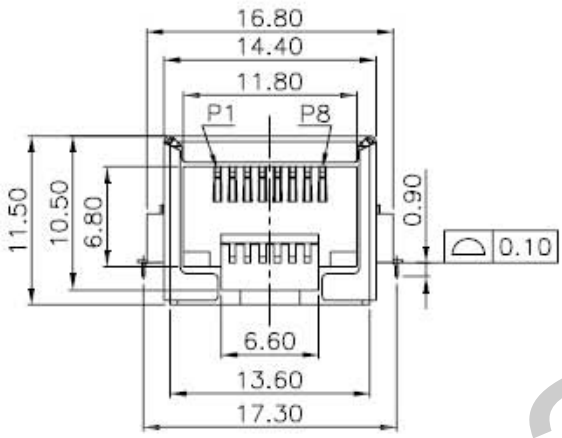

RECOMMENDED PCB LAYOUT  
GENERAL TOLERANCE ±0.05

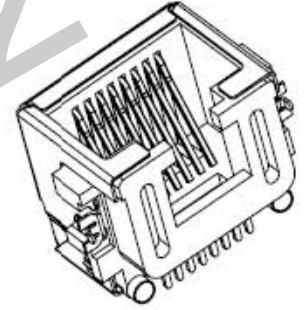
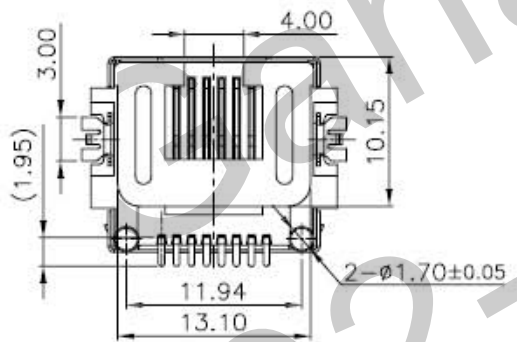

◎◎ : Inspection Item ◎P : Cp/Cpk and SPC Control Item ◎P : APPROVE ◎P : CHECK	DIMENSION IN mm [Inch]		HDC 有限公司	
	TOLERANCE UNLESS OTHERWISE SPECIFIED		图号 FILE NO.	料号 DWG NO.
	.X± 0.20	X.*± 1'	GRJJ-H7186	
	.XX± 0.15	.X.*± 0.5'	名称 TITLE SMT 1X1 8P8C Embedded PCB JACK WITH SHIELDED H=8.65MM ,SIDE ENTRY,FLAT PIN	
.XXX± 0.075		制图 DRAW	审核 CHECK	比例 SCALE 1:1 图幅 SIZE A3 张数 SHEET 1 / 1 核准 REV A
		Oscar		