

更改 REV	修改内容 MODIFICATION	日期 DATE	制图 DRAW	核准 APPROVE
A	图纸发行	2012/10/29	JDL	Oscar

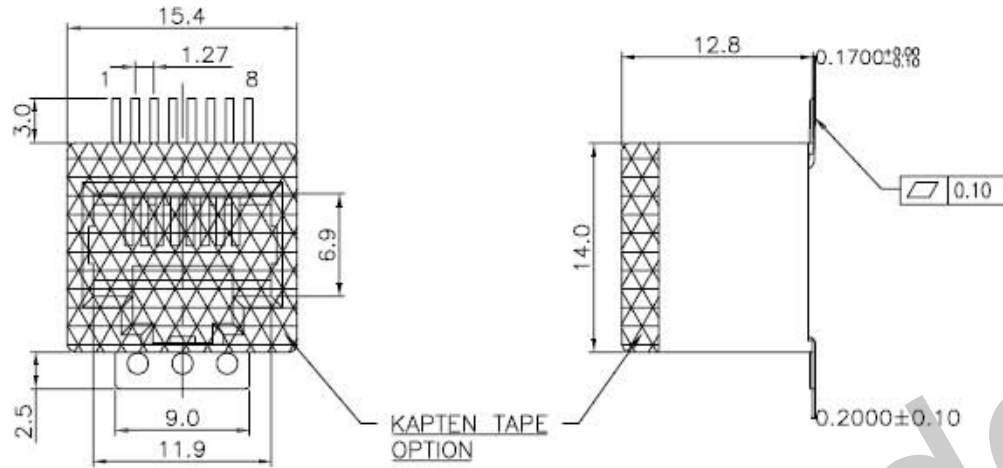

NOTES:

ELECTRICAL:

- VOLTAGE RATING : 125 VAC RMS.
- CURRENT RATING : 1.5 AMP.
- CONTACT RESISTANCE : 30 MILLIOHMS MAX.
- INSULATION RESISTANCE: 1000 MEGOHMS MIN @ 500 VDC.
- DIELECTRIC STRENGTH : 1000 VAC RMS 60Hz, 1MIN.

MECHANICAL:

- HOUSING MATERIAL: NYLON+GF30% UL94V-0./COLOR:BLACK
- CONTACT MATERIAL: PHOSPHOR BRONZE t=0.35mm.
- SHIELD MATERIAL: 0.35mm THICKNESS BRASS; PLATING NICKEL.
- PLATING : GOLD PLATING OVER NICKEL.
- OPERATING LIFE : 750 CYCLES MIN.
- PCB RETENTION POST-SOLDER: 10 LBS MIN.

ENVIRONMENTAL:

- STORAGE : -40°C TO +85°C.
 - OPERATION: -40°C TO +85°C.
 - IR REFLOW PEAK SOLDERING TEMPERATURE : 255°C TO 265°C (5~10 SECONDS).
 - RoHS COMPLIANT.
- MATES WITH MODULAR PLUG CONFORMING TO FCC PART 68, SUBPART F.

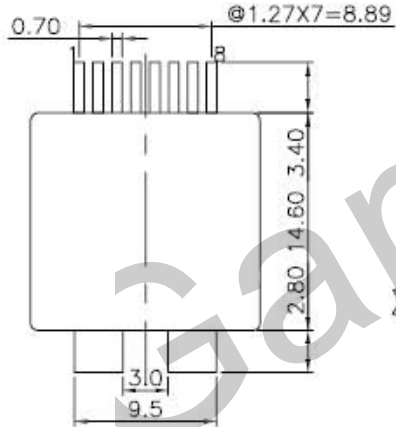

PCB LAYOUT (COMPONENT SIDE VIEW)

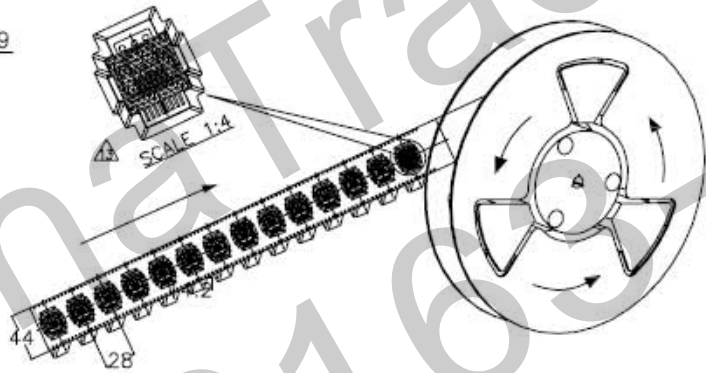

QC : Inspection Item Cpk/Cpk and SPC Control Item	DIMENSION IN mm [Inch]		HDC 有限公司	
	TOLERANCE UNLESS OTHERWISE SPECIFIED		图号 FILE NO.	料号 DWG NO.
	.X± 0.20	X.*± 1*	GRJJ-H7188	
	.XX± 0.15	.X*± 0.5*	名称 TITLE	
.XXX± 0.075		SMT 1X1 8P8C PCB JACK WITH UNSHIELDED H=12.7MM ,TOP ENTRY,FLAT PIN		
核准 APPROVE	审核 CHECK	制图 DRAW	画法 PROJ.	张数 SHEET
		Oscar	比例 SCALE	1 / 1
			1:1	A3
			图幅 SIZE	更改 REV
				A