

更改 REV	更改内容 MODIFICATION	日期 DATE	制图 DRAW	审核 APPROVE
A	图纸发行	2012/10/29	JDL	Oscar

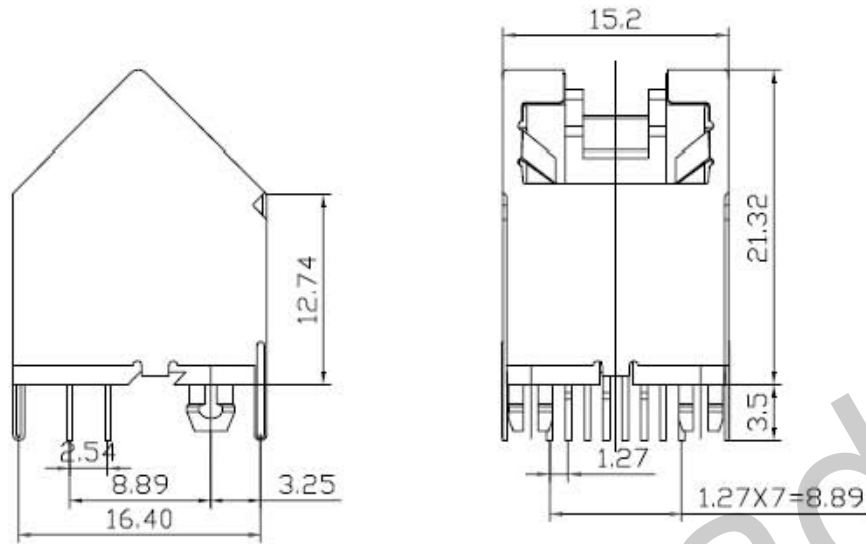

NOTES:

ELECTRICAL:

1. VOLTAGE RATING : 125 VAC RMS.
2. CURRENT RATING : 1.5 AMP.
3. CONTACT RESISTANCE : 50 MILLIOHMS MAX.
4. INSULATION RESISTANCE: 500 MEGOHMS MIN @ 500 VDC.
5. DIELECTRIC STRENGTH : 1000 VAC RMS 50Hz, 1MIN.

MECHANICAL:

1. HOUSING MATERIAL : GLASS FILLED POLYESTER UL94V-0
2. CONTACT MATERIAL : PHOSPHOR BRONZE $\phi 0.46$ mm.
3. PLATING : GOLD PLATING OVER NICKEL.
4. SHIELD : COPPER ALLOY (OR STEEL ALLOY) 0.20mm THICKNESS PLATING NI.
5. OPERATING LIFE : 750 CYCLES MIN.
6. PCB RETENTION PRE-SOLDER : 1 LB MIN.
7. PCB RETENTION POST-SOLDER: 10 LBS MIN.

ENVIRONMENTAL:

1. STORAGE : -40°C TO $+85^{\circ}\text{C}$.
2. OPERATION: -40°C TO $+85^{\circ}\text{C}$.
3. ROHS COMPLIANT

MATES WITH MODULAR PLUG CONFORMING TO FCC PART 68, SUBPART F.

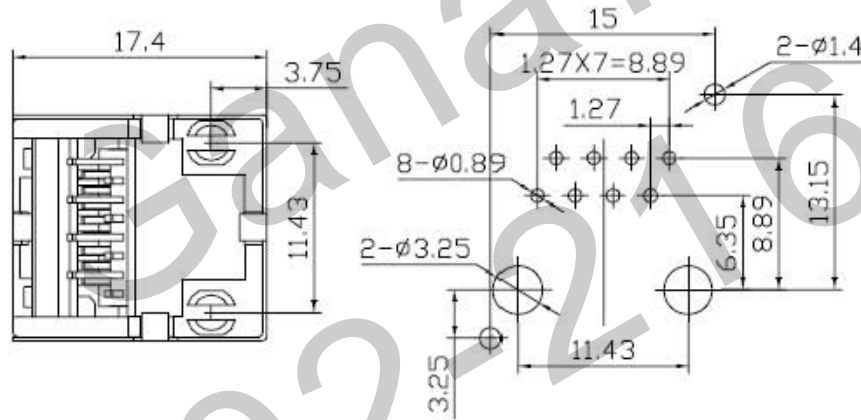

PC Board Layout
Component Side Shown



QC : Inspection Item	Cp/Cpk and SPC Control Item	DIMENSION IN mm [Inch]		HDC 有限公司			
		TOLERANCE UNLESS OTHERWISE SPECIFIED		文件号 FILE NO.	图号 DWG NO. GRJJ-H7189		
		.X \pm 0.20	X.* \pm 1*	名称 TITLE 52F 1X1 BP8C PCB JACK WITH SHIELD 45* TDP ENTRY, FLAT PIN			
		.XX \pm 0.15	.X.* \pm 0.5*	图号 DRAW Oscar			
XXX \pm 0.075		审核 APPROVE	检查 CHECK	制图 DRAW Oscar	比例 SCALE 1:1		
				图幅 SIZE A3	张数 SHEET 1 / 1		
				更改 REV A			