

1 2 3 4 5 6 7 8

更改 REV	设计内容 MODIFICATION	日期 DATE	制图 DRAW	审核 APPROVE
A	图面发行	2012/10/29	JDL	Oscar

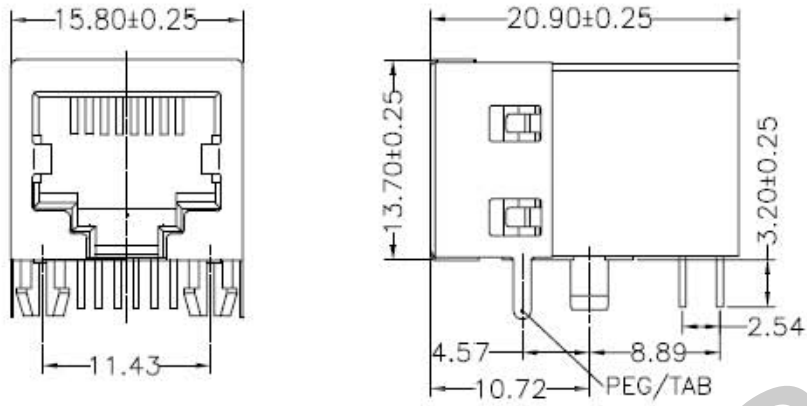

**NOTES:**

**ELECTRICAL:**

- 1. VOLTAGE RATING : 125 VAC RMS.
- 2. CURRENT RATING : 1.5 AMP.
- 3. CONTACT RESISTANCE : 50 MILLIOHMS MAX.
- 4. INSULATION RESISTANCE: 500 MEGOHMS MIN @ 500 VDC.
- 5. DIELECTRIC STRENGTH : 1000 VAC RMS 50Hz, 1MIN.

**MECHANICAL:**

- 1. HOUSING MATERIAL : NYLON+30%.G.F UL94V-0.
- 2. CONTACT MATERIAL : PHOSPHOR BRONZE  $\phi$ 0.46mm.
- 3. PLATING : GOLD PLATING OVER NICKEL.
- 4. SHIELD: COPPER ALLOY(OR STEEL ALLOY) 0.20mm THICKNESS PLATING NI.
- 5. LED:OPTION
- 6. OPERATING LIFE : 750 CYCLES MIN.
- 7. PCB RETENTION PRE-SOLDER : 1 LB MIN.
- 8. PCB RETENTION POST-SOLDER: 10 LBS MIN.

**ENVIRONMENTAL:**

- 1. STORAGE : -40°C TO +85°C.
- 2. OPERATION: 0°C TO +70°C.
- 3. WAVE SOLDERING TEMPERATURE: 255~265° (5~10SECONDS).
- 4. ROHS COMPLIANT

MATES WITH MODULAR PLUG CONFORMING TO FCC PART 68, SUBPART F.

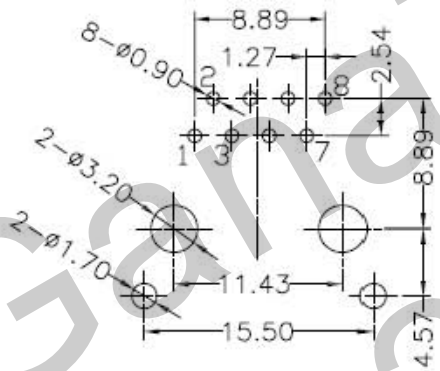

PC Board Layout

QC : Inspection Item	Cpk and SPC Control Item	DIMENSION IN mm [Inch]		<b>HDC 有限公司</b>	
		TOLERANCE UNLESS OTHERWISE SPECIFIED		图号 FILE NO.	图号 DWG NO.
		.X± 0.20	X."± 1"	59A 1X1 8PBC PCB JACK HALF SHIELDED SIDE ENTRY,ROUND PIN	
		.XX± 0.15	.X"± 0.5"	GRJJ-H7193	
.XXX± 0.075		制图 DRAW	审核 CHECK	比例 SCALE	图幅 SIZE
		Oscar		1:1	A3
				1/1	A

1 2 3 4 5 6 7 8