

更改 REV	变更内容 MODIFICATION	日期 DATE	制图 DRAW	审核 APPROVE
A	首次发行	2012/10/29	JDL	Oscar

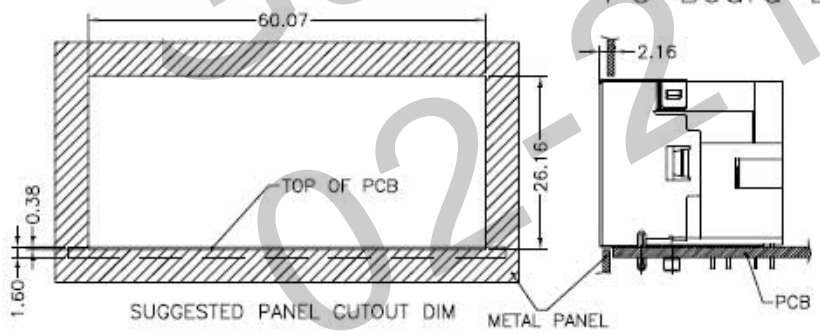
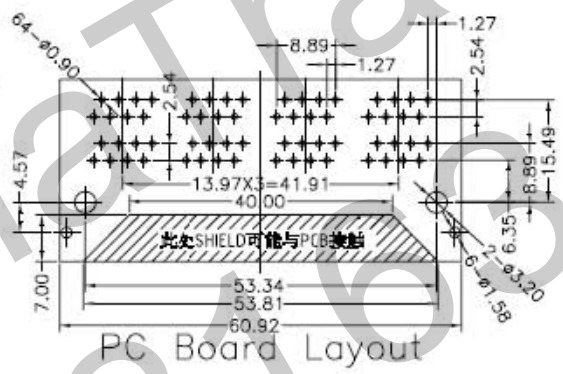
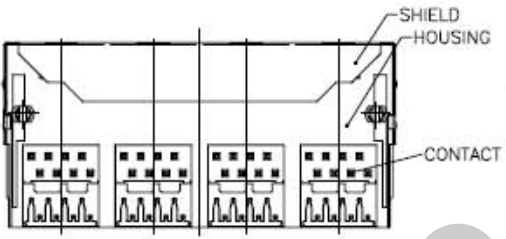
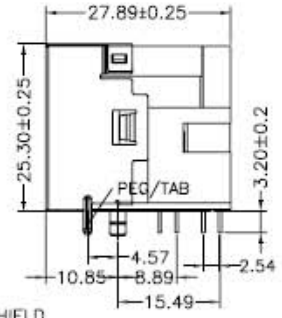
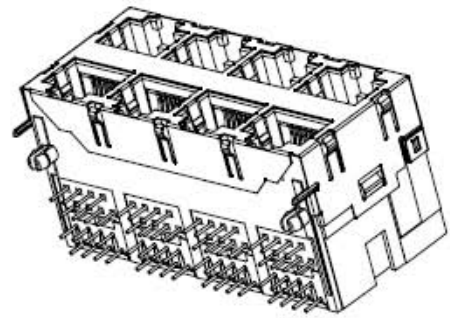
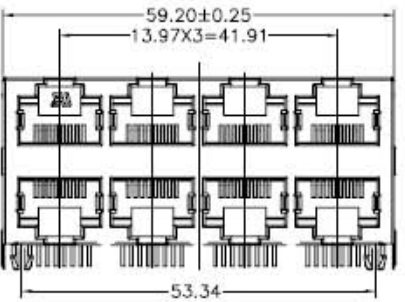

NOTES:

MATERIAL:

- HOUSING MATERIAL :GLASS FILLED POLYESTER(UL94V-0).
- CONTACT MATERIAL :PHOSPHOR BRONZE Ø0.46mm (C5100).
- PLATING :GOLD PLATING OVER NICKEL.
- SHIELD: COPPER ALLOY 0.20mm THICKNESS PLATING NI.

ELECTRICAL:

- VOLTAGE RATING :125 VAC RMS.
- CURRENT RATING :1.5 AMP.
- CONTACT RESISTANCE :50 MILLIOHMS MAX.
- INSULATION RESISTANCE :500 MEGOHMS MIN @ 500V DC.
- DIELECTRIC WITHSTANDING RESISTANCE :1000V AC RMS 50Hz. 1MIN.

MECHANICAL:

- DURRABILITY :750 CYCLES MIN.
- PCB RETENTION PRE-SOLDER :1 LB MIN.

ENVIRONMENTAL:

- STORAGE :-40°C TO +85°C.
- OPERATION : 0°C TO 70°C.

MATES WITH MODULAR PLUG CONFORMING TO FCC PART 68,SUBPART F.

QC : inspection item Cp/Cpk and SPC Control item	DIMENSION IN mm [Inch]		HDC 有限公司	
	TOLERANCE UNLESS OTHERWISE SPECIFIED		料单号 FILE NO.	料号 DWG NO. GRJJ-H7196
	.X± 0.20	.X"± 1"	名称 TITLE 59A 2X4 8P8C PCB JACK & HALF SHIELDED W/O EMI FINGER SIDE ENTRY,ROUND PIN	
	.XX± 0.15	.X"± 0.5"		
.XXX± 0.075		制图 DRAW Oscar	审核 PROJ. 1/1	数量 SHEET 1/1
核准 APPROVE	审核 CHECK	比例 SCALE 1:1	图幅 SIZE A3	更改 REV A