

更改 REV	变更内容 MODIFICATION	日期 DATE	制图 DRAW	审核 APPROVE
A	图纸发行	2012/10/29	JDL	Oscar

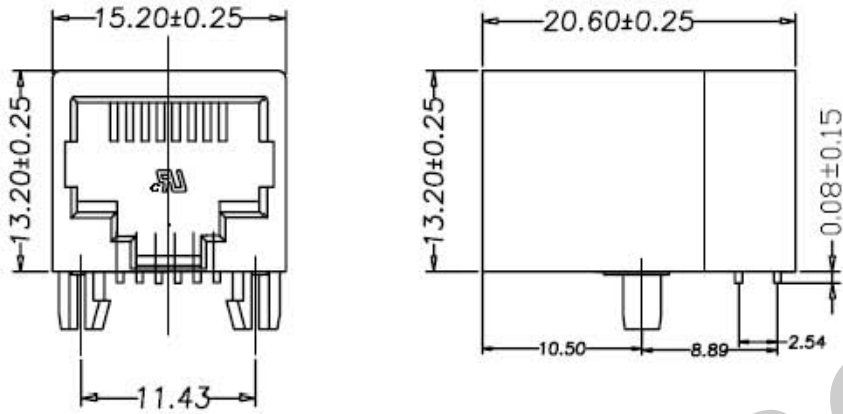

NOTES:

ELECTRICAL:

- VOLTAGE RATING : 125 VAC RMS.
- CURRENT RATING : 1.5 AMP.
- CONTACT RESISTANCE : 50 MILLIOHMS MAX.
- INSULATION RESISTANCE: 500 MEGOHMS MIN @ 500 VDC.
- DIELECTRIC STRENGTH : 1000 VAC RMS 50Hz, 1MIN.

MECHANICAL:

- HOUSING MATERIAL : NYLON+30%.G.F UL94V-0.
- CONTACT MATERIAL : PHOSPHOR BRONZE @0.46mm.
- PLATING : GOLD PLATING OVER NICKEL.
- SHIELD COPPER ALLOY(OR STEEL ALLOY) 0.20mm THICKNESS PLATING NI.
- LED:OPTION
- OPERATING LIFE : 750 CYCLES MIN.
- PCB RETENTION PRE-SOLDER : 1 LB MIN.
- PCB RETENTION POST-SOLDER: 10 LBS MIN.

ENVIRONMENTAL:

- STORAGE : -40°C TO +85°C.
 - OPERATION: 0°C TO +70°C.
 - WAVE SOLDERING TEMPERATURE: 255°~265° (5~10SECONDS).
 - ROHS COMPLIANT
- MATES WITH MODULAR PLUG CONFORMING TO FCC PART 68, SUBPART F.

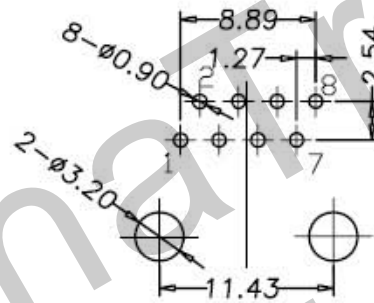

PC Board Layout

QC : Inspection Item	Cp/Cpk and SPC Control Item	DIMENSION IN mm [Inch]		HDC 有限公司		
		TOLERANCE UNLESS OTHERWISE SPECIFIED		料号 FILE NO.	图号 DWG NO.	GRJJ-H7198
		.X± 0.20	X.*± 1*	名称 TITLE 59A 1X1 BPBC WIRE SOLDER JACK W/O SHIELD SIDE ENTRY,ROUND PIN		
		.XX± 0.15	.X*± 0.5*			
.XXX± 0.075		制图 DRAW Oscar	审核 PROJ SCALE 1:1	图幅 SHEET A3	数量 REV 1 / A	