

更改 REV	变更内容 MODIFICATION	日期 DATE	制图 DRAW	审核 APPROVE
A	首版发行	2012/10/29	JDL	Oscar

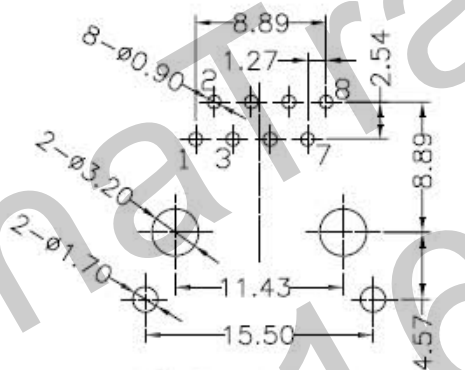
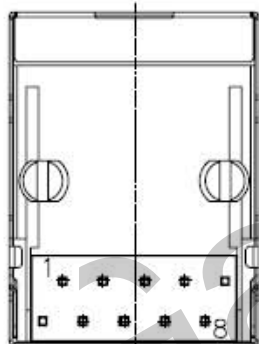
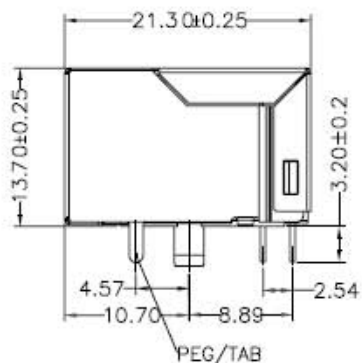
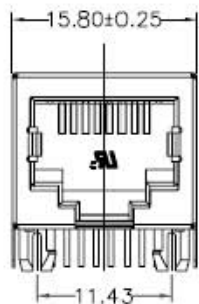

PC Board Layout

**NOTES:**

**ELECTRICAL:**

- VOLTAGE RATING : 125 VAC RMS.
- CURRENT RATING : 1.5 AMP.
- CONTACT RESISTANCE : 50 MILLIOHMS MAX.
- INSULATION RESISTANCE: 500 MEGOHMS MIN @ 500 VDC.
- DIELECTRIC STRENGTH : 1000 VAC RMS 50Hz, 1MIN.

**MECHANICAL:**

- HOUSING MATERIAL : NYLON+30%.G.F UL94V-0.
- CONTACT MATERIAL : PHOSPHOR BRONZE ø0.46mm.
- PLATING : GOLD PLATING OVER NICKEL.
- SHIELD: COPPER ALLOY(OR STEEL ALLOY) 0.20mm THICKNESS PLATING NI.
- LED:OPTION
- OPERATING LIFE : 750 CYCLES MIN.
- PCB RETENTION PRE-SOLDER : 1 LB MIN.
- PCB RETENTION POST-SOLDER: 10 LBS MIN.

**ENVIRONMENTAL:**

- STORAGE : -40°C TO +85°C.
  - OPERATION: 0°C TO +70°C.
  - WAVE SOLDERING TEMPERATURE: 255~265° (5~10SECONDS).
  - ROHS COMPLIANT
- MATES WITH MODULAR PLUG CONFORMING TO FCC PART 68, SUBPART F.

QC : Inspection Item		DIMENSION IN mm [Inch]		HDC 有限公司	
Cp/Cpk and SPC Control Item	TOLERANCE UNLESS OTHERWISE SPECIFIED			图号 FILE NO.	图号 DWG NO. GRJJ-H7205
	.X± 0.20	X."± 1"		名称 TITLE 59A 1X1 8PBC PCB JACK WITH SHIELDED SIDE ENTRY,ROUND PIN	
	.XX± 0.15	.X"± 0.5"			
	.XXX± 0.075				
核准 APPROVE	审核 CHECK	制图 DRAW Oscar	画法 PROJ.	张数 SHEET 1 / 1	比例 SCALE 1:1
			图幅 SIZE A3	更改 REV A	