

F
E
D
C
B
A

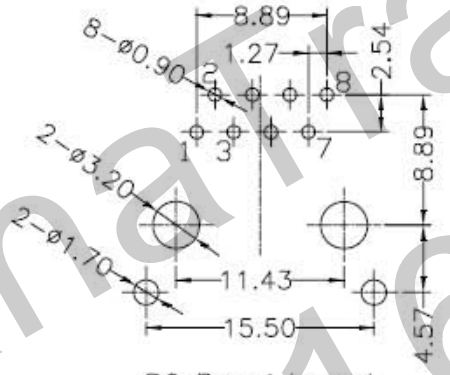

PC Board Layout

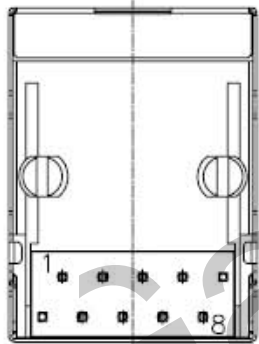
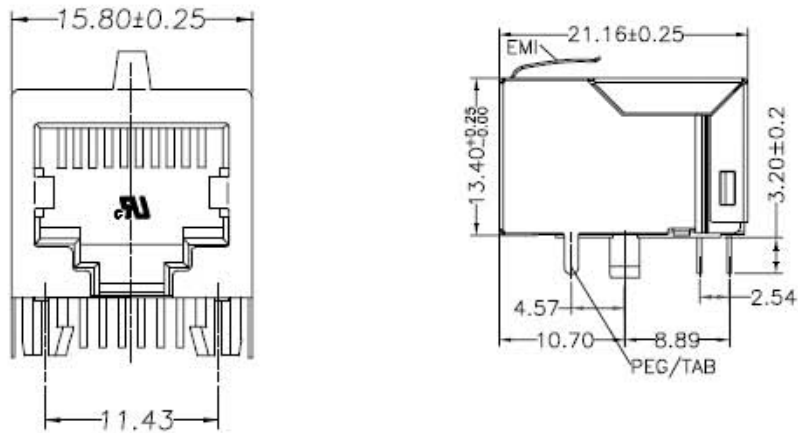
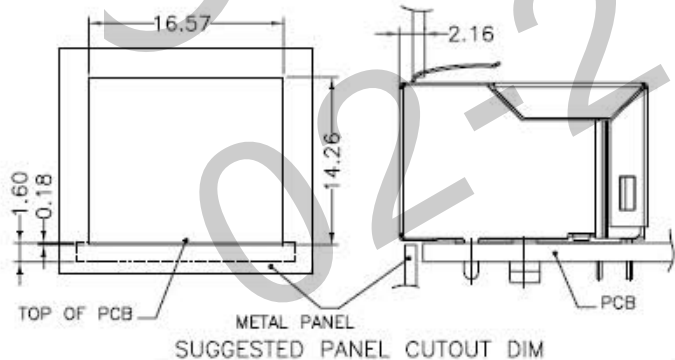

SUGGESTED PANEL CUTOUT DIM



REV	设计内容 MODIFICATION	日期 DATE	制图 DRAW	审核 APPROVE
A	图纸发行	2012/10/29	JDL	Oscar

NOTES:

ELECTRICAL:

- VOLTAGE RATING : 125 VAC RMS.
- CURRENT RATING : 1.5 AMP.
- CONTACT RESISTANCE : 50 MILLIOHMS MAX.
- INSULATION RESISTANCE: 500 MEGOHMS MIN @ 500 VDC.
- DIELECTRIC STRENGTH : 1000 VAC RMS 50Hz, 1MIN.

MECHANICAL:

- HOUSING MATERIAL : NYLON+30% G.F UL94V-0.
- CONTACT MATERIAL : PHOSPHOR BRONZE ∅0.46mm.
- PLATING : GOLD PLATING OVER NICKEL.
- SHIELD: COPPER ALLOY (OR STEEL ALLOY) 0.20mm THICKNESS PLATING NI.
- LED: OPTION
- OPERATING LIFE : 750 CYCLES MIN.
- PCB RETENTION PRE-SOLDER : 1 LB MIN.
- PCB RETENTION POST-SOLDER: 10 LBS MIN.

ENVIRONMENTAL:

- STORAGE : -40°C TO +85°C.
- OPERATION: 0°C TO +70°C.
- WAVE SOLDERING TEMPERATURE: 255°~265° (5~10SECONDS).
- ROHS COMPLIANT

MATES WITH MODULAR PLUG CONFORMING TO FCC PART 68, SUBPART F.

Inspection Item		DIMENSION IN mm [Inch]		HDC 有限公司		
Cp/Cpk and SPC Control Item	TOLERANCE UNLESS OTHERWISE SPECIFIED	文件号 FILE NO.	图号 DWG NO.	GRJJ-H7207		
	.X± 0.20	X.*± 1"	标题 TITLE 59A 1X1 8P8C PCB JACK & SHIELDED WITH A BACK WARD EMI FINGER, SIDE ENTRY, ROUND PIN			
	.XX± 0.15	.X*± 0.5"	制图 DRAW Oscar			
	.XXX± 0.075		方法 PROJ. 1:1 比例 SCALE 1:1			
CPK	制图 DRAW	审核 CHECK	制图 DRAW	方法 PROJ.	审核 SHEET 1 / 1	
				比例 SCALE	图幅 SIZE A3	
					审核 REV A	

1 2 3 4 5 6 7 8