

更改 REV	设计内容 MODIFICATION	日期 DATE	制图 DRAW	审核 APPROVE
A	图纸发行	2012/10/29	JDL	Oscar

NOTES:

ELECTRICAL:

- VOLTAGE RATING : 125 VAC RMS.
- CURRENT RATING : 1.5 AMP.
- CONTACT RESISTANCE : 50 MILLIOHMS MAX.
- INSULATION RESISTANCE: 500 MEGOHMS MIN @ 500 VDC.
- DIELECTRIC STRENGTH : 1000 VAC RMS 50Hz, 1MIN.

MECHANICAL:

- HOUSING MATERIAL : NYLON+30%.G.F UL94V-0.
- CONTACT MATERIAL : PHOSPHOR BRONZE ϕ 0.46mm
- PLATING : GOLD PLATING OVER NICKEL.
- SHIELD: COPPER ALLOY(OR STEEL ALLOY) 0.20mm THICKNESS PLATING NI.
- LED:OPTION
- OPERATING LIFE : 750 CYCLES MIN.
- PCB RETENTION PRE-SOLDER : 1 LB MIN.
- PCB RETENTION POST-SOLDER: 10 LBS MIN.

ENVIRONMENTAL:

- STORAGE : -40°C TO +85°C.
- OPERATION: 0°C TO +70°C.
- WAVE SOLDERING TEMPERATURE: 255°~265° (5~10SECONDS).
- ROHS COMPLIANT

MATES WITH MODULAR PLUG CONFORMING TO FCC PART 68, SUBPART F.

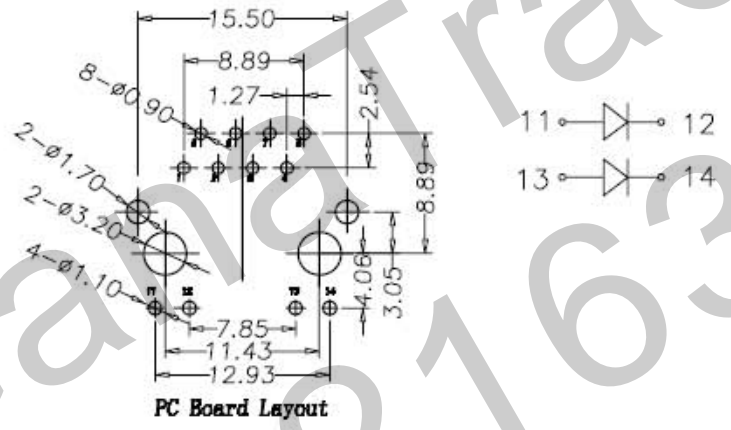
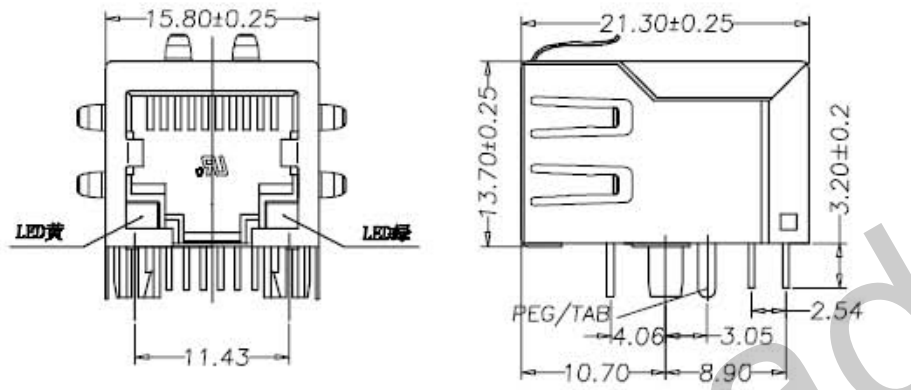

F
E
D
C
B
A

381163-01

QC : Inspection Item	Cpk : Cp/Cpk and SPC Control Item	DIMENSION IN mm [Inch]		HDC 有限公司	
		TOLERANCE UNLESS OTHERWISE SPECIFIED		文件号 FILE NO.	图号 DWG NO.
		.X± 0.20	X."± 1"	GRJ-H7209	
		.XX± 0.15	.X"± 0.5"	名称 TITLE	
.XXX± 0.075		59A 1X1 8P8C LED PCB JACK SHIELDED WITH BACKWARD EMI FINGER, SIDE ENTRY, ROUND PIN			
制图 DRAW	审核 CHECK	制图 DRAW	审核 CHECK	比例 SCALE	图幅 SIZE
Oscar		Oscar		1:1	A3
				张数 SHEET	共张 REV
				1 / 1	A