

更改 REV	變更內容 MODIFICATION	日期 DATE	繪圖 DRAW	檢核 APPROVE
A	圖面發行	2012/10/29	JDL	Oscar

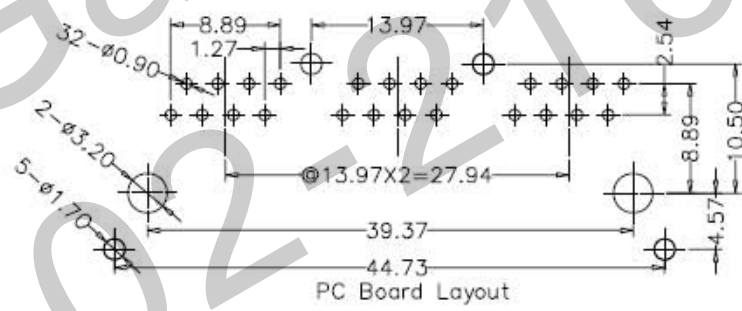
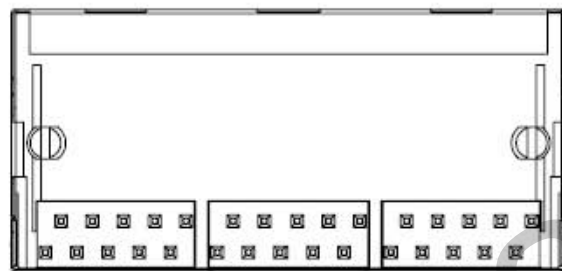
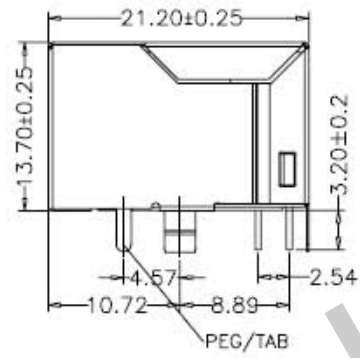
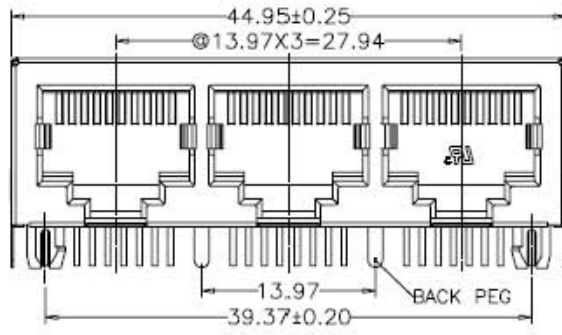

NOTES:

ELECTRICAL:

- VOLTAGE RATING : 125 VAC RMS.
- CURRENT RATING : 1.5 AMP.
- CONTACT RESISTANCE : 50 MILLIOHMS MAX.
- INSULATION RESISTANCE: 500 MEGOHMS MIN @ 500 VDC.
- DIELECTRIC STRENGTH : 1000 VAC RMS 50Hz, 1MIN.

MECHANICAL:

- HOUSING MATERIAL : NYLON+30%.G.F UL94V-0.
- CONTACT MATERIAL : PHOSPHOR BRONZE φ0.46mm.
- PLATING : GOLD PLATING OVER NICKEL.
- SHIELD: COPPER ALLOY(OR STEEL ALLOY) 0.20mm THICKNESS PLATING NI.
- LED:OPTION
- OPERATING LIFE : 750 CYCLES MIN.
- PCB RETENTION PRE-SOLDER : 1 LB MIN.
- PCB RETENTION POST-SOLDER: 10 LBS MIN.

ENVIRONMENTAL:

- STORAGE : -40°C TO +85°C.
- OPERATION: 0°C TO +70°C.
- WAVE SOLDERING TEMPERATURE: 255°~265° (5~10SECONDS).
- ROHS COMPLIANT

MATES WITH MODULAR PLUG CONFORMING TO FCC PART 68, SUBPART F.

QC : Inspection Item Cp/Cpk and SPC Control Item	DIMENSION IN mm [Inch]		HDC 有限公司	
	TOLERANCE UNLESS OTHERWISE SPECIFIED		專案號 FILE NO.	圖號 DWG NO. GRJJ-H7213
	.X± 0.20	X.°± 1°	名稱 TITLE 59A 1X3 BPBC PCB JACK WITH SHIELDED SIDE ENTRY,ROUND PIN	
	.XX± 0.15	.X°± 0.5°		
.XXX± 0.075		繪圖 DRAW Oscar	圖號 PROJ. 1 / 1	圖紙 SHEET 1 / 1
核准 APPROVE	檢查 CHECK	比例 SCALE 1:1	圖幅 SIZE A3	更改 REV A