

更改 REV	更改内容 MODIFICATION	日期 DATE	制图 DRAW	审核 APPROVE
A	图画发布	2012/10/29	JDL	Oscar

NOTES:

ELECTRICAL:

- VOLTAGE RATING : 125 VAC RMS.
- CURRENT RATING : 1.5 AMP.
- CONTACT RESISTANCE : 50 MILLIOHMS MAX.
- INSULATION RESISTANCE: 500 MEGOHMS MIN @ 500 VDC.
- DIELECTRIC STRENGTH : 1000 VAC RMS 50Hz, 1MIN.

MECHANICAL:

- HOUSING MATERIAL : NYLON+30%.G.F UL94V-0.
- CONTACT MATERIAL : PHOSPHOR BRONZE ϕ 0.46mm.
- PLATING : GOLD PLATING OVER NICKEL.
- SHIELD: COPPER ALLOY(OR STEEL ALLOY) 0.20mm THICKNESS PLATING NI.
- LED:OPTION
- OPERATING LIFE : 750 CYCLES MIN.
- PCB RETENTION PRE-SOLDER : 1 LB MIN.
- PCB RETENTION POST-SOLDER: 10 LBS MIN.

ENVIRONMENTAL:

- STORAGE : -40°C TO +85°C.
- OPERATION: 0°C TO +70°C.
- WAVE SOLDERING TEMPERATURE: 255°~265° (5~10SECONDS).
- ROHS COMPLIANT

MATES WITH MODULAR PLUG CONFORMING TO FCC PART 68, SUBPART F.

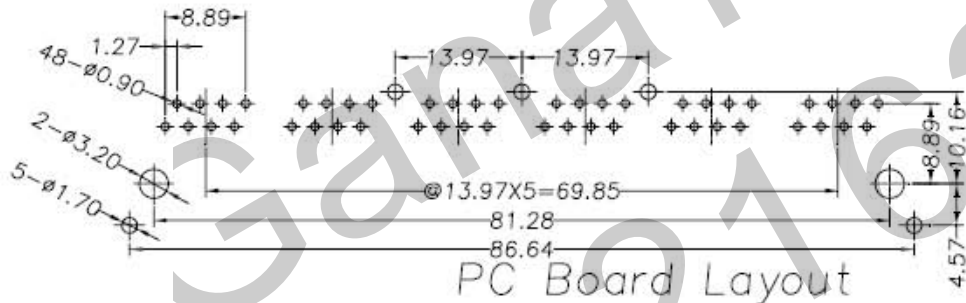
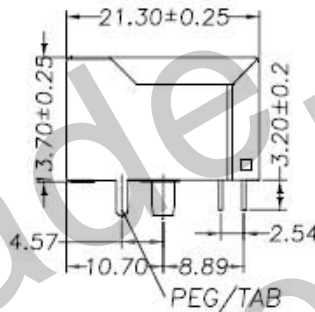
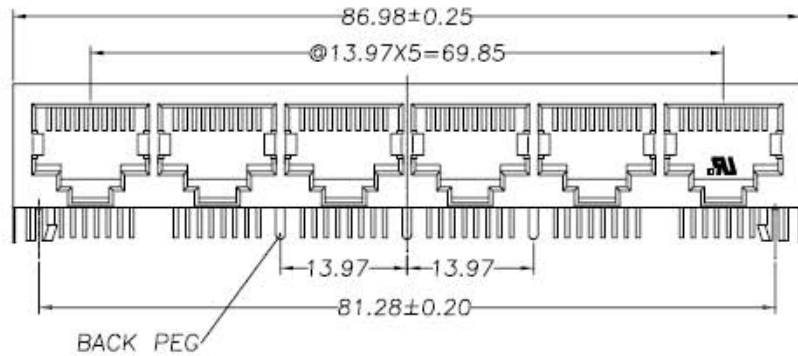

PC Board Layout

QC : Inspection Item	Cp/Cpk and SPC Control Item	DIMENSION IN mm [Inch]		HDC 有限公司	
		TOLERANCE UNLESS OTHERWISE SPECIFIED		档案号 FILE NO.	图号 DWG NO.
		.X \pm 0.20	X.* \pm 1*	名称 TITLE	
		.XX \pm 0.15	.X* \pm 0.5*	59A 1X6 BP8C PCB JACK WITH SHIELDED SIDE ENTRY,ROUND PIN	
		.XXX \pm 0.075		制图 DRAW	审核 SHEET
批准 APPROVE	检查 CHECK	制图 DRAW		比例 SCALE	张数 REV
		Oscar		1:1	1 / 1 A