

更改 REV	设计内容 MODIFICATION	日期 DATE	制图 DRAW	审核 APPROVE
A	批量发行	2012/10/29	JDL	Oscar

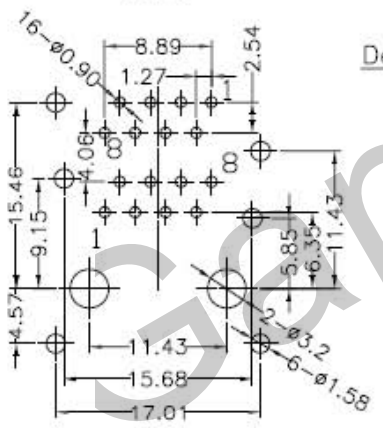

PC Board Layout

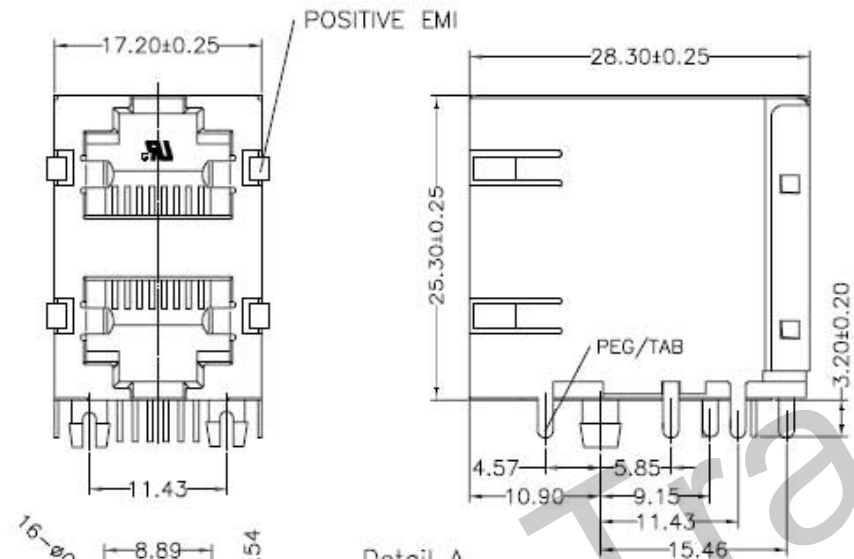
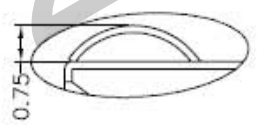
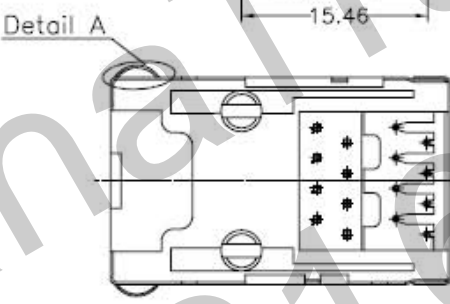

Detail A

NOTES:

- MATERIAL:
- HOUSING MATERIAL :GLASS FILLED POLYESTER(UL94V-0).
  - CONTACT MATERIAL :PHOSPHOR BRONZE ø0.46mm (C5100).
  - PLATING :GOLD PLATING OVER NICKEL.
  - SHIELD.COPPER ALLOY 0.20mm THICKNESS PLATING NI.
- ELECTRICAL:
- VOLTAGE RATING :125 VAC RMS.
  - CURRENT RATING :1.5 AMP.
  - CONTACT RESISTANCE :50 MILLIOHMS MAX.
  - INSULATION RESISTANCE :500 MEGOHMS MIN @ 500V DC.
  - DIELECTRIC WITHSTANDING RESISTANCE :1000V AC RMS 50Hz. 1MIN.
- MECHANICAL:
- DURABILITY :750 CYCLES MIN.
  - PCB RETENTION PRE-SOLDER :1 LB MIN.
- ENVIRONMENTAL:
- STORAGE : -40°C TO +85°C.
  - OPERATION : 0°C TO 70°C.
- MATES WITH MODULAR PLUG CONFORMING TO FCC PART 68,SUBPART F.

QC : Inspection Item	DIMENSION IN mm [Inch]		HDC 有限公司	
	TOLERANCE UNLESS OTHERWISE SPECIFIED		零件号 FILE NO.	图号 DWG NO. GRJJ-H7220
	.X±0.20	X."± 1"	名称 TITLE 59A 2X1 8P8C PCB JACK&SHIELDED WITH EMI FINGER SIDE ENTRY,ROUND PIN	
	.XX±0.15	.X"± 0.5"		
.XXX±0.075		制图 DRAW Oscar	审核 PROJ.	数量 SHEET 1 / 1
批准 APPROVE	检查 CHECK	比例 SCALE 1:1	图幅 SIZE A3	更改 REV A