

更改 REV	变更内容 MODIFICATION	日期 DATE	制图 DRAW	审核 APPROVE
A	图纸发行	2012/10/29	JDL	Oscar

NOTES:

ELECTRICAL:

- VOLTAGE RATING : 125 VAC RMS.
- CURRENT RATING : 1.5 AMP.
- CONTACT RESISTANCE : 50 MILLIOHMS MAX.
- INSULATION RESISTANCE: 500 MEGOHMS MIN @ 500 VDC.
- DIELECTRIC STRENGTH : 500 VAC RMS 50Hz, 1MIN.

MECHANICAL:

- HOUSING MATERIAL : NYLON(PA46)+30%G.F UL94V-0.
- CONTACT MATERIAL : PHOSPHOR BRONZE T=0.35mm (C5210)
- PLATING : GOLD-PLATED IN THE CONTACT AREA
- SHIELD: COPPER ALLOY(OR STEEL ALLOY) 0.20mm THICKNESS
- OPERATING LIFE : 750 CYCLES MIN.
- PCB RETENTION PRE-SOLDER : 1 LB MIN.
- PCB RETENTION POST-SOLDER: 10 LBS MIN.

ENVIRONMENTAL:

- STORAGE : -40°C TO +85°C.
  - OPERATION: 0°C TO +70°C.
  - IR REFLOW PEAK SOLDERING TEMPERATURE: 255°C~265°C 5~10 SECONDS.
  - ROHS COMPLIANT
- FCC PART 68, SUBPART F.  
MATES WITH MODULAR PLUG CONFORMING TO

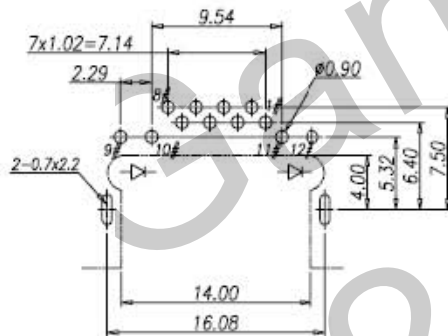
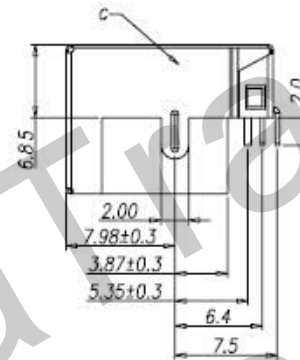
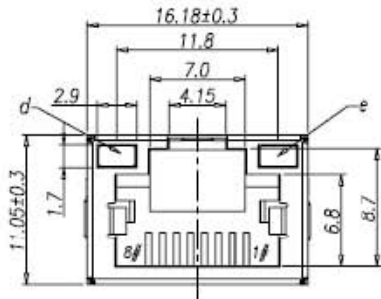
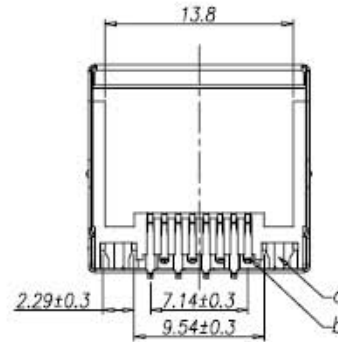
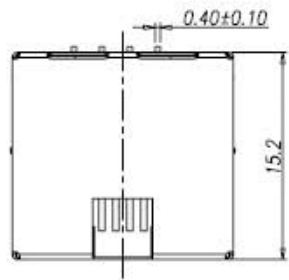

Recommend PCB Layout  
(Jack Top View)  
Tolerance: ±0.05mm

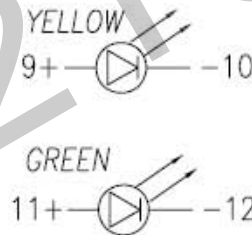

QC : Inspection Item	Cpk/Cpk and SPC Control Item	DIMENSION IN mm [Inch]		HDC 有限公司	
		TOLERANCE UNLESS OTHERWISE SPECIFIED		料號 FILE NO.	圖號 DWG NO.
		.X± 0.20	.X*± 1"	GRJJ-H7244	
		.XX± 0.15	.X*± 0.5"	名稱 TITLE	
.XXX± 0.075		DIP TYPE, 1X1 8PBC Embedded PCB JACK&SHIELDED WITH LED H=6.85MM ,SIDE ENTRY,TAB-UP,FLAT PIN			
核准 APPROVE	審核 CHECK	制图 DRAW	繪圖 SCALE	比例 SCALE	圖紙 SIZE
		Oscar	1:1	1:1	A3
				頁數 SHEET	1 / 1
				更改 REV	A