

更改 REV	设定内容 MODIFICATION	日期 DATE	制图 DRAW	核准 APPROVE
A	图面发行	2012/10/29	JDL	Oscar

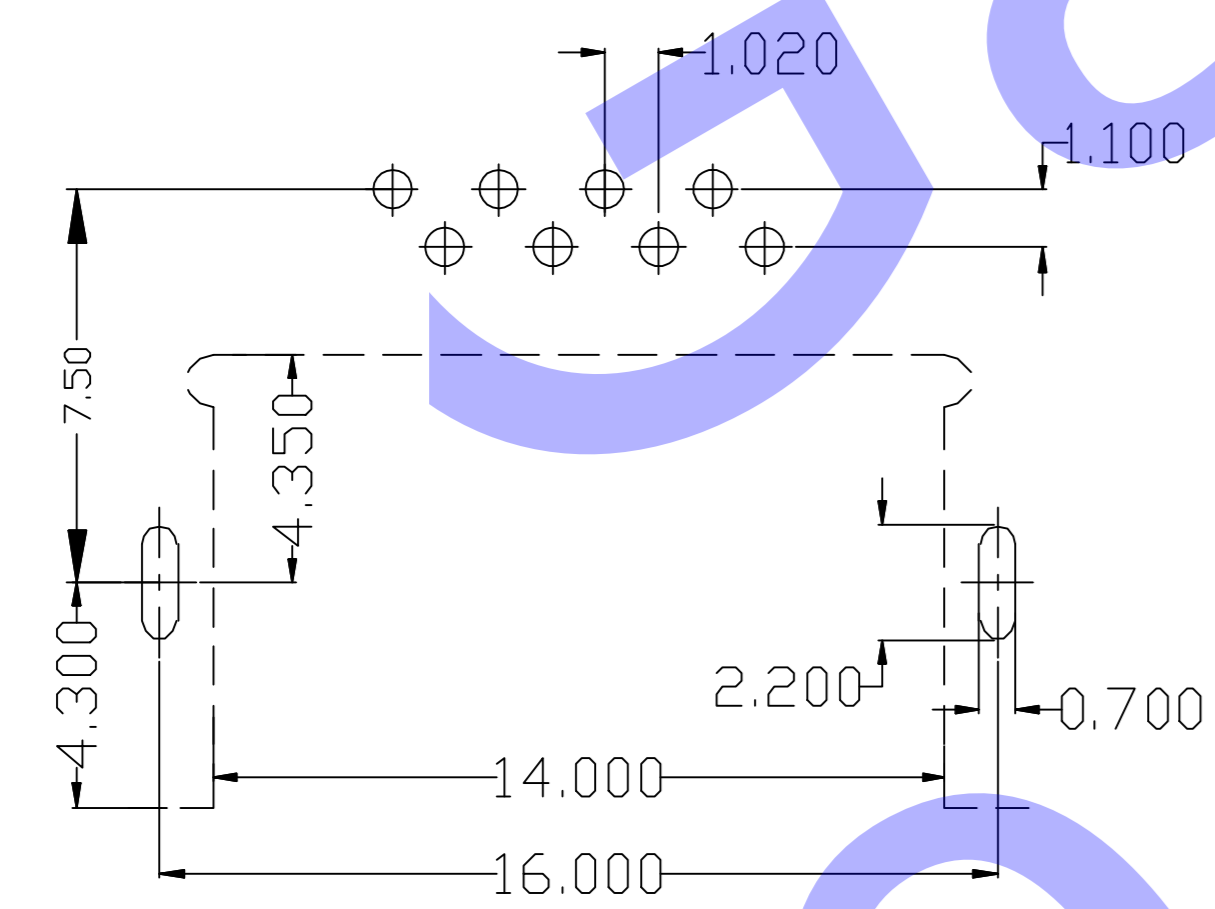

Recommend PCB Layout
(Jack Top View)
Tolerance: ±0.05mm

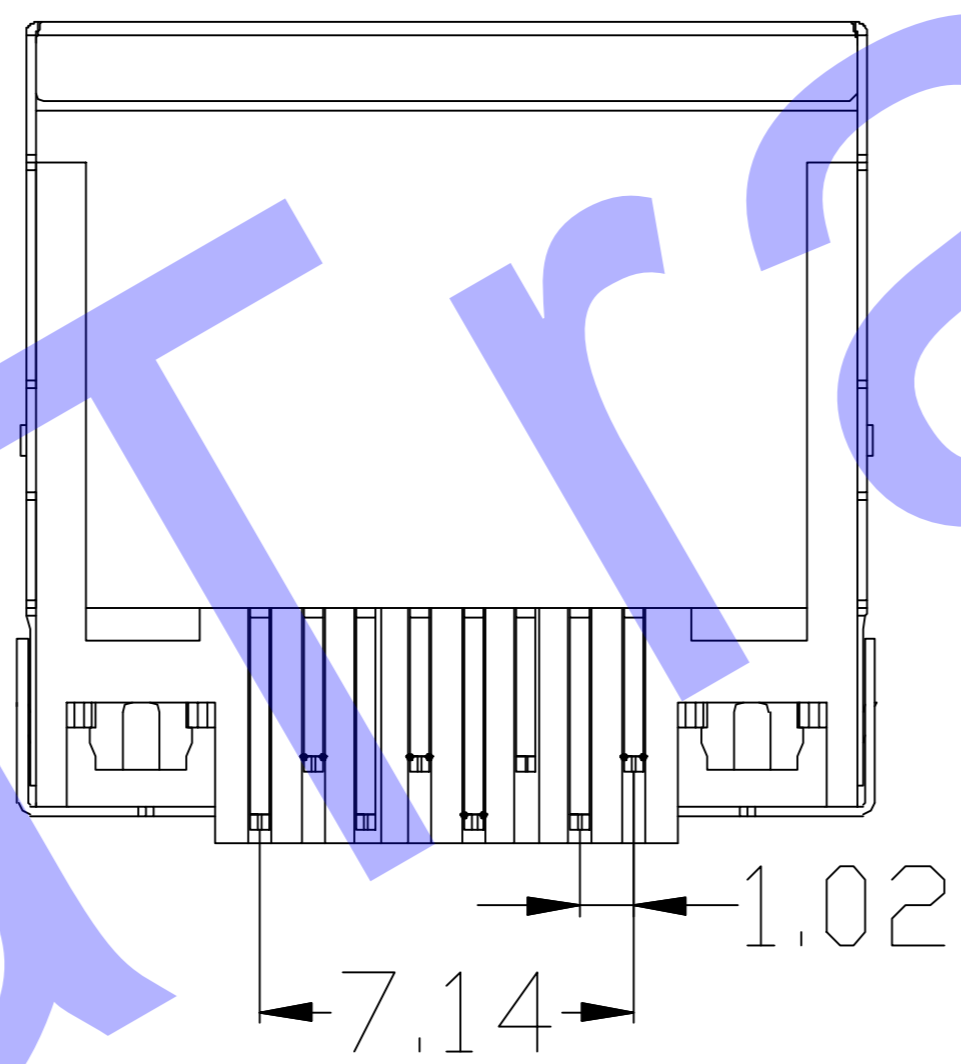
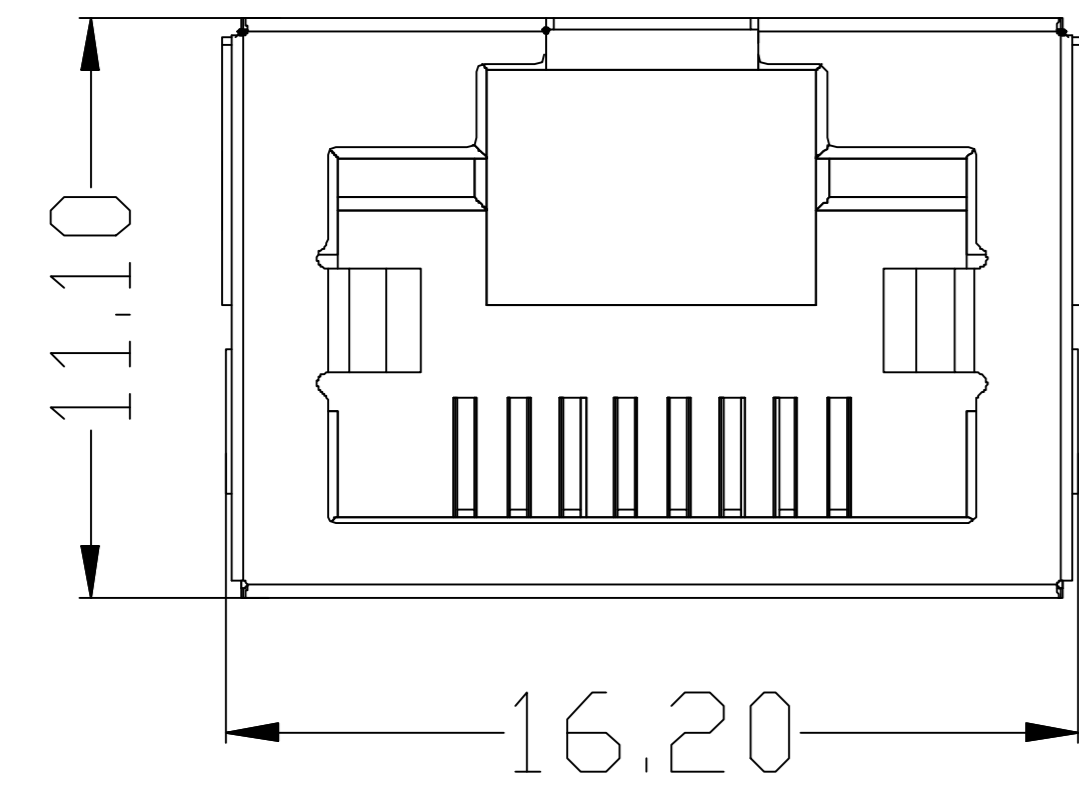
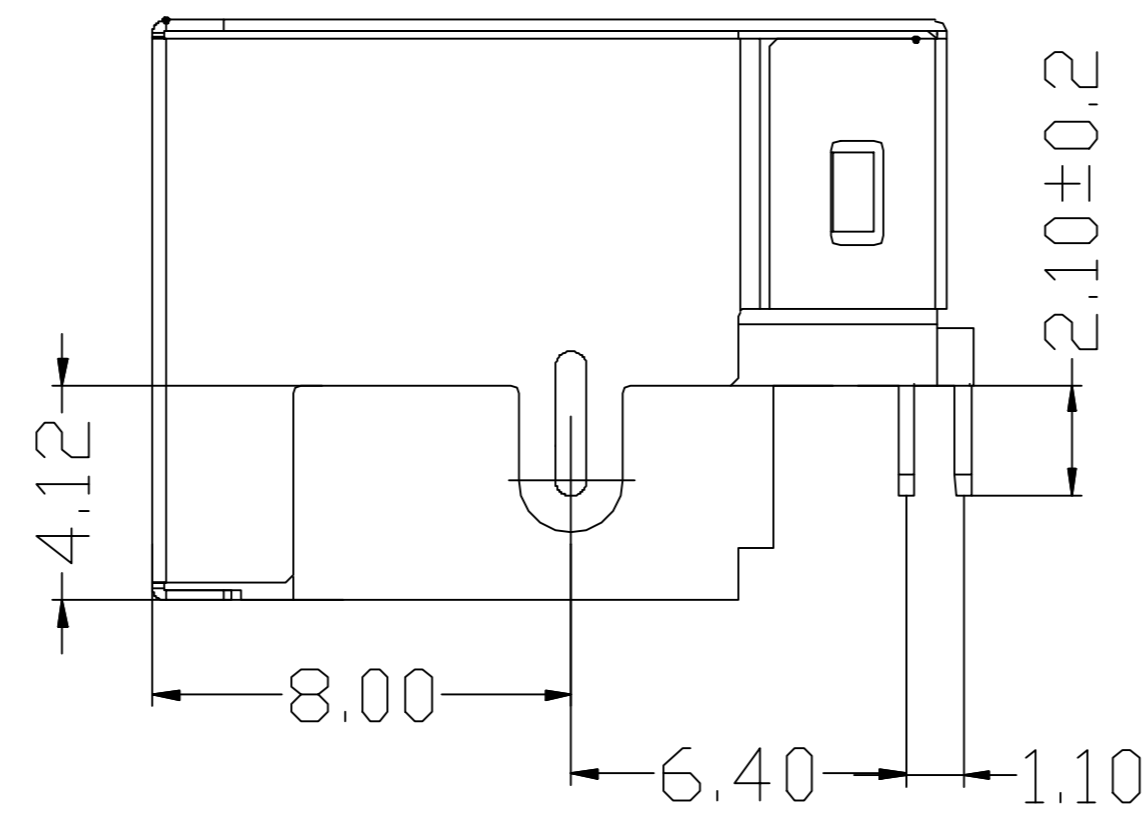
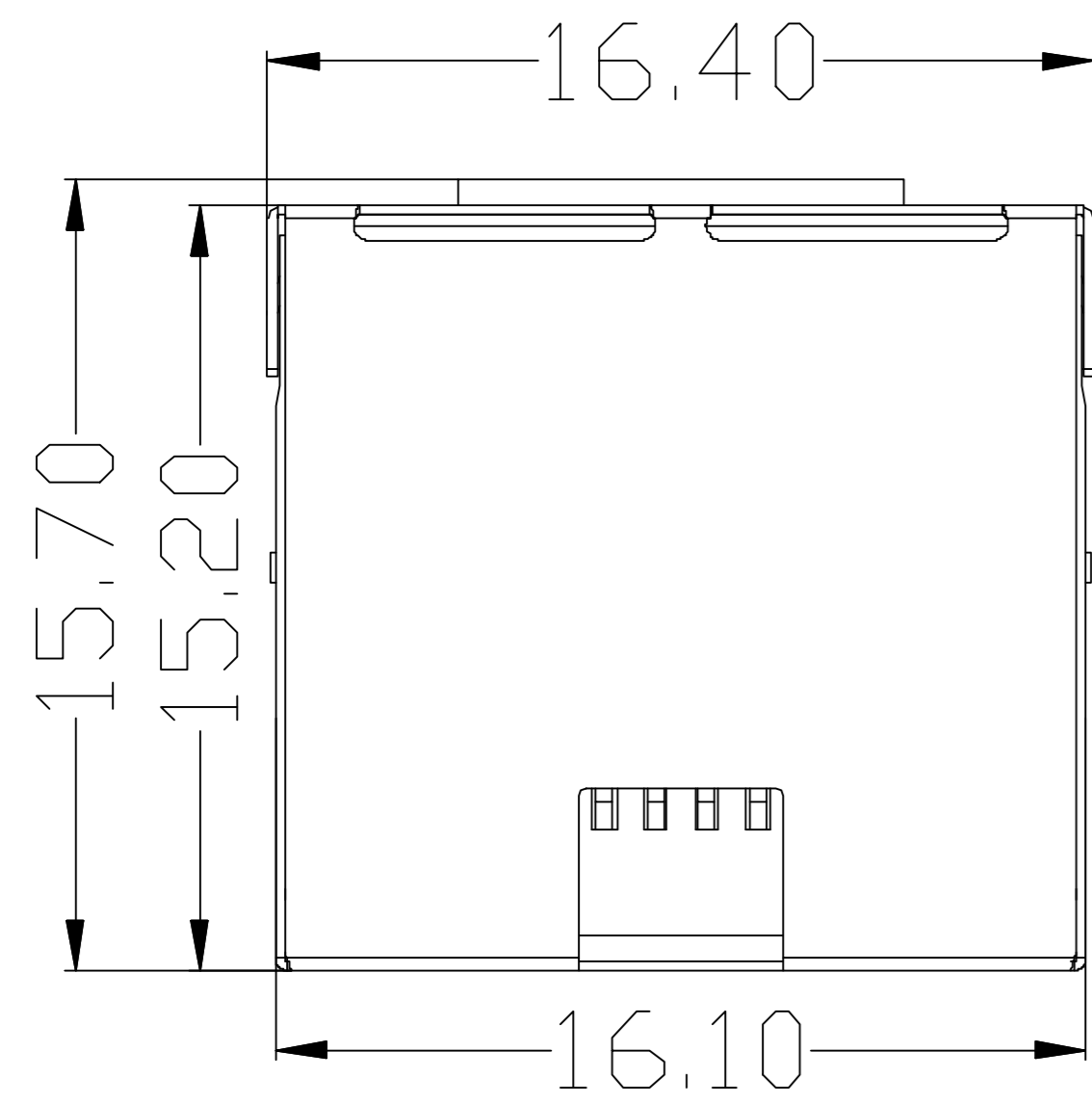
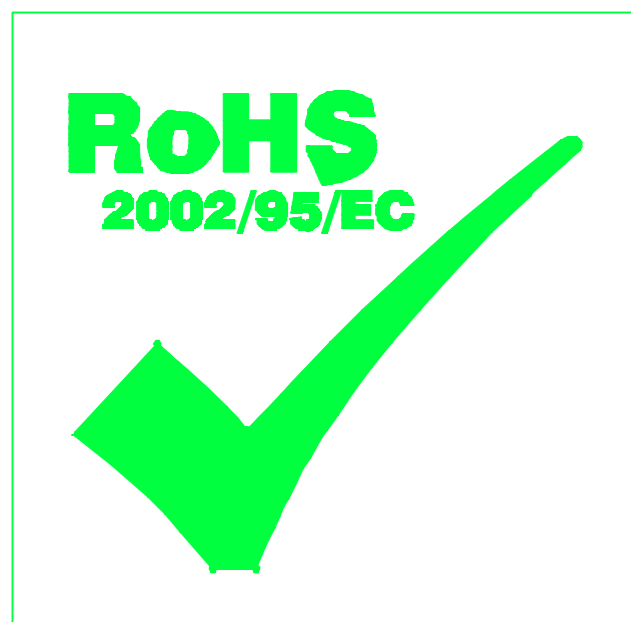

NOTES:

ELECTRICAL:

- 1. VOLTAGE RATING : 125 VAC RMS.
- 2. CURRENT RATING : 1.5 AMP.
- 3. CONTACT RESISTANCE : 50 MILLIOHMS MAX.
- 4. INSULATION RESISTANCE: 500 MEGOHMS MIN @ 500 VDC.
- 5. DIELECTRIC STRENGTH : 500 VAC RMS 50Hz, 1MIN.

MECHANICAL:

- 1. HOUSING MATERIAL : NYLON(PA46)+30%.G.F UL94V-0.
- 2. CONTACT MATERIAL : PHOSPHOR BRONZE T=0.35mm (C5210)
- 3. PLATING : GOLD-PLATED IN THE CONTACT AREA
- 4. SHIELD: COPPER ALLOY(OR STEEL ALLOY) 0.20mm THICKNESS
- 5. OPERATING LIFE : 750 CYCLES MIN.
- 6. PCB RETENTION PRE-SOLDER : 1 LB MIN.
- 7. PCB RETENTION POST-SOLDER: 10 LBS MIN.

ENVIRONMENTAL:

- 1. STORAGE : -40°C TO +85°C.
 - 2. OPERATION: 0°C TO +70°C.
 - 3. IR REFLOW PEAK SOLDERING TEMPERATURE:255°C~265°C 5~10 SECONDS.
 - 4. ROHS COMPLIANT
- FCC PART 68, SUBPART F.
MATES WITH MODULAR PLUG CONFORMING TO

PART NUMBER: DIPE-S1188L0-H2XX

GOLD PLATING U"
1-Fu" 2-2u" 3-3u" 4-6u"
5-15u" 6-30u"

PLASTIC MATERIAL&COLOR:Black/Yellow/Gray
1-PBT+20%GF Black
2-PA46 Black
3-LCP Black

QC : Inspection Item	Cp/Cpk and SPC Control Item	DIMENSION IN mm [Inch]		HDC 有限公司			
		TOLERANCE UNLESS OTHERWISE SPECIFIED		专案号 FILE NO.	图号 DWG NO. YL DIPE-S1188L0-H2		
		.X± 0.20	X.°± 1°	名称 TITLE DIP TYPE, 1X1 8P8C Embedded PCB JACK&SHIELDED H=6.95MM ,SIDE ENTRY,TAB-UP,FLAT PIN			
		.XX± 0.15	.X°± 0.5°				
.XXX± 0.075		制图 DRAW Oscar	角法 PROJ. 比例 SCALE 1:1	图号 SIZE A3	页数 SHEET 1 / 1	更改 REV A	