

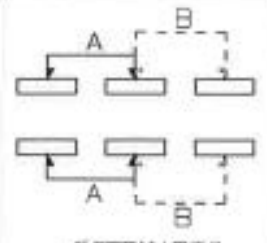

RoHS
Compliance

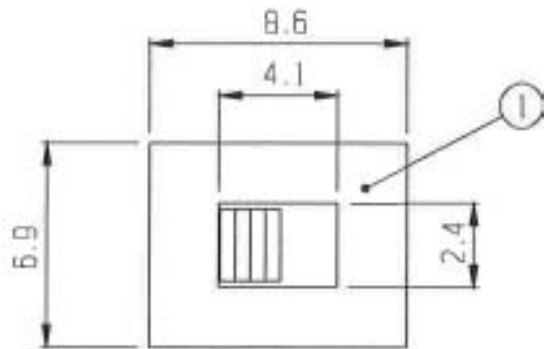

SCHMATIC

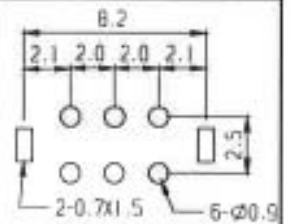

PCB LAYOUT

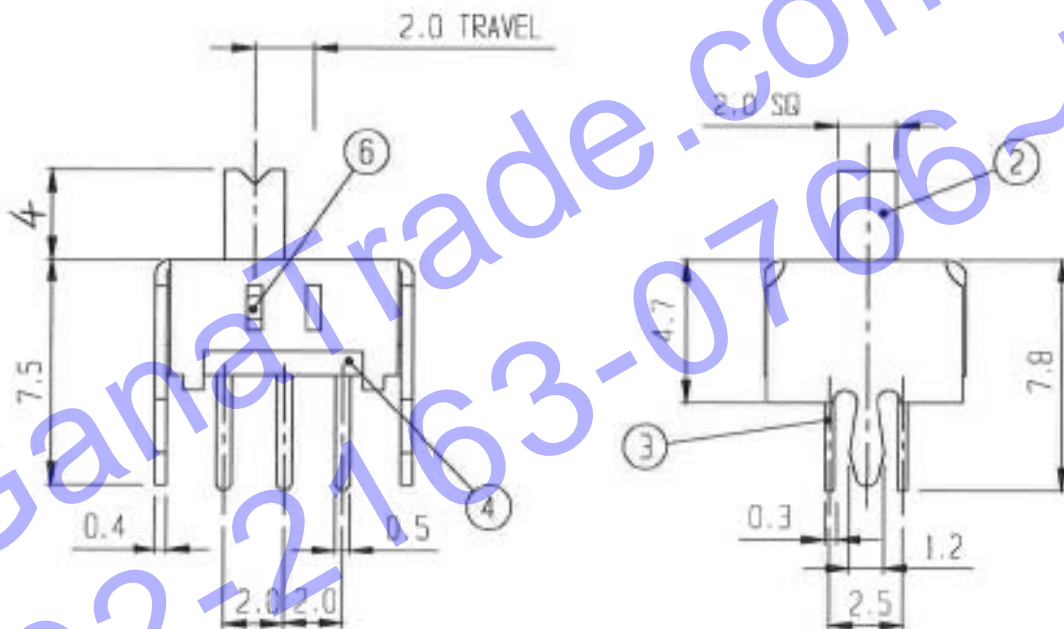

| | | | | | | | | | |
|----|----------|----------|-----|-----------|----|---------------|--------------|-----|---------|
| 5 | CONTACT | P B S | 2 | Ag PLATED | 6 | SPRING | P B S | 1 | |
| 3 | TERMINAL | BRASS | 6 | Ag PLATED | 4 | TERMINAL BASE | PHENOL RESIN | 1 | |
| 1 | FRAME | S P C C | 1 | Ni PLATED | 2 | KNOB | P O M | 1 | |
| NO | PART | MATERIAL | QTY | REMARKS | NO | PART | MATERIAL | QTY | REMARKS |

ISSUED

SPECIFICATION

TITLE: SLIDE SWITCH (2P2T)

RATING: DC 30V 0.3A

MODEL NO: SS-22D03-VG4

CONTACT RESISTANCE: 30mΩ max.

INSULATION RESISTANCE: 500MΩ at 500V DC

TOLERANCE UNIT: MM

WITHSTAND VOLTAGE: AC 500V for 1 minute

UP TO 1.0:±0.1 SCALE: 4:1

OPERATION FORCE: REFER ATTACH SPECIFICATION

1.0 TO 10.0:±0.2 VERSION: 01

SWITCHING LIFE: 10K cycles min.

OVER 10.0:±0.3 DRWG NO:

BY: *Gregson*

DATE: 06-NOV-2009

H D C 有 限 公 司

