

版本	变更内容	变更人	日期
A			

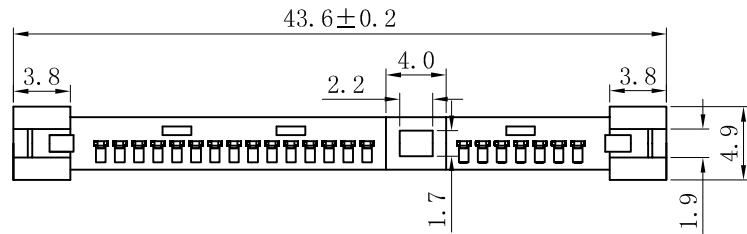

SPECIFICATIONS

MATERIAL:

HOUSING: LCP UL94V-0

COLOR: BLACK

CONTACT: PHOSPHOR BRONZE

PEG: BRASS

FINISH: CONTACT: 3U" GOLD/TIN PLATING ON CONTACT AREA

100U"MIN. TIN-LEAD PLATING ON SOLDER TAILS

50U"MIN. NICKEL UNDERPLATING OVER ALL.

PEG: 100U"MIN. TIN-LEAD PLATING ON SOLDER TAILS

50U"MIN. NICKEL UNDERPLATING OVER ALL.

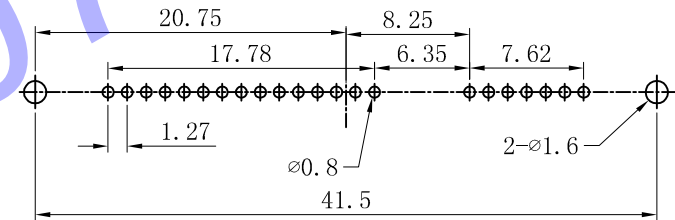
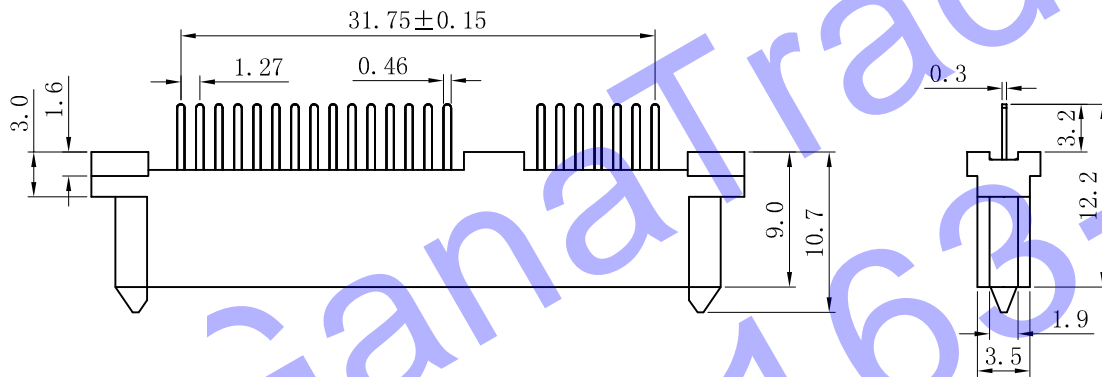

PCB LAYOUT

PCB LAYOUT

X.	±0.3	X.*	±1.0*	客户:	产品名称: SATA 7+15 夹板胶芯180° 不带鱼叉	HDC ELECTRONICS CO., LTD.				
.X	±0.25	.X*	±0.5*							
.XX	±0.2	.XX*	±0.2*			单位: MM	产品料号: GSTA - 715F - 04	核准:	日期:	
.XXX	±0.05	.XXX*	±0.1*					审核:	日期:	
				材质:	图 号:	数量:	比例: 1:1	版次: A	设计: 康春香	日期: 09-07-10