

REV	ECN NO	DESCRIPTION	DATE	NAME
A		NEW		

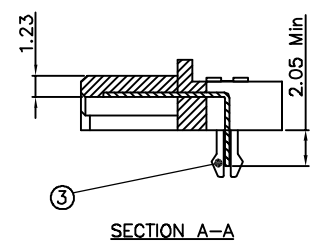

SPECIFICATION:

- 1.MATERIAL:
 HOUSING:LCP UL94V-0
 COLOR:BLACK
 CONTACT:BRASS C2680R-H,T=0.25mm
 PEG:BRASS C2680R-H,T=0.30mm
- 2.FINISH:
 CONTACT: 1u" GOLD/TIN PLATING ON CONTACT AREA
 100u" MIN. TIN PLATING ON SOLDERTAILS
 50u" MIN. NICKEL UNDERPLATING OVERALL
 PEG:100u" MIN. TIN PLATING ON SOLDERTAILS
 50u" MIN. NICKEL UNDERPLATING OVERALL

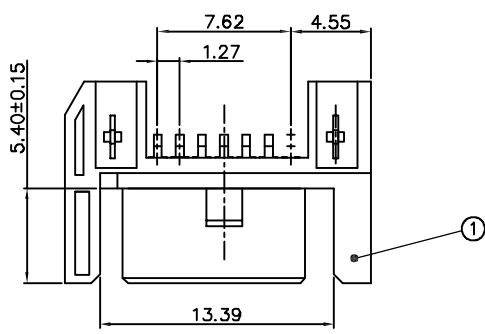
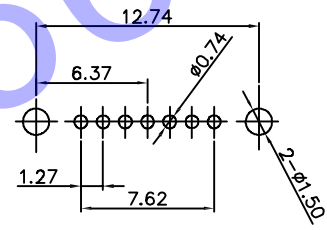
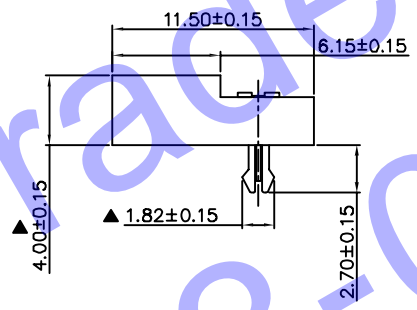
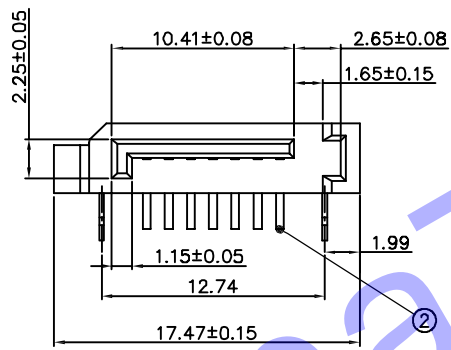

P.C BOARD LAYOUT

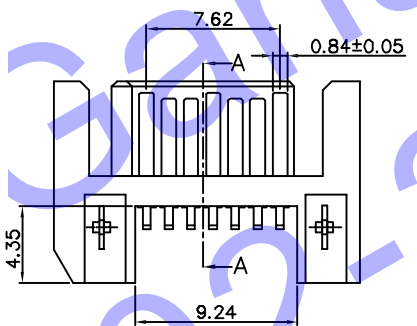

HDC ELECTRONICS CO., LTD.

TITLE	SATA 7P DIP 90	DRAWN BY	Zeng_	11.08.08
PART NO	GSTA-7M-01	CHECKED BY		
DRAWING NO		APPROVED BY		
SCALE	1:1	UNITE	mm	PAGE
				SIZE
				A4

TOLERANCE UNLESS OTHERWISE SPECIFIED	
LINER	ANGLES
.0 ±0.30	0.° ±3°
.00 ±0.25	.0° ±2°
.000 ±0.15	.00° ±1°