

1102K

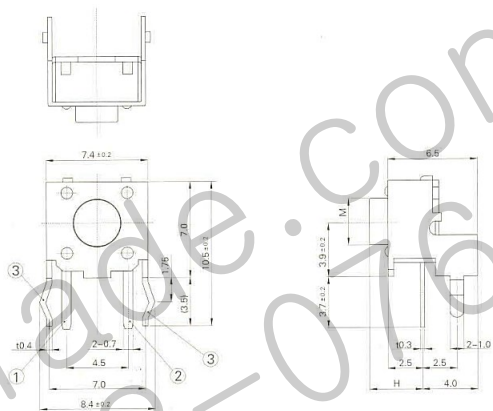

SPECIFICATION

1. RATING : DC 12V 50mA
2. CONTACT RESISTANCE : 100mΩ MAX.
3. TRAVEL : 0.25 ± 0.1mm
4. BOUNCE : 10m SEC MAX.
- 5.

MODEL	OPERATING FORCE	LIFE CYCLES	
1102K -0, 0S	100 ± 30gf	80,000	1,000,000
1102K -1, 1S	130 ± 30gf	80,000	1,000,000
1102K -2, 2S	160 ± 50gf	80,000	1,000,000
1102K -3, 3S	250 ± 50gf	50,000	300,000
1102K -4, 4S	350 ± 80gf	50,000	200,000
1102K -5, 5S	500 ± 100gf	30,000	100,000

CIRCUIT DIAGRAM

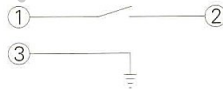

P.C.B MOUNTING HOLES

