

1107

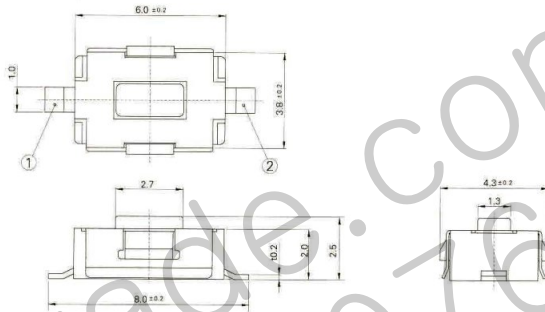
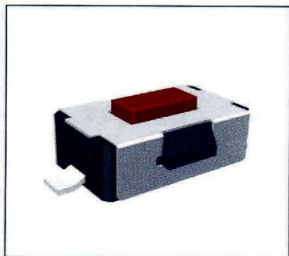

## SPECIFICATION

1. RATING : DC 12V 50mA
2. CONTACT RESISTANCE : 100mΩ MAX.
3. TRAVEL : 0.25 ± 0.1mm
4. BOUNCE : 10m SEC MAX.

MODEL	OPERATING FORCE	LIFE CYCLES
1107 -1	130 ± 30gf	50,000 CYCLE
1107 -2	180 ± 50gf	50,000 CYCLE
1107 -3	250 ± 50gf	30,000 CYCLE

## CIRCUIT DIAGRAM



## P.C.B LAND PATTERN

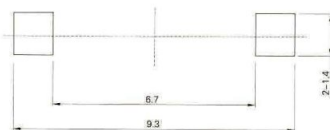

PACKING

## REEL TYPE

1107(With Embossing)	1107E(With Embossing)
3,000/1 REEL(EA)	3,000/1 REEL(EA)

