

# 1110GV

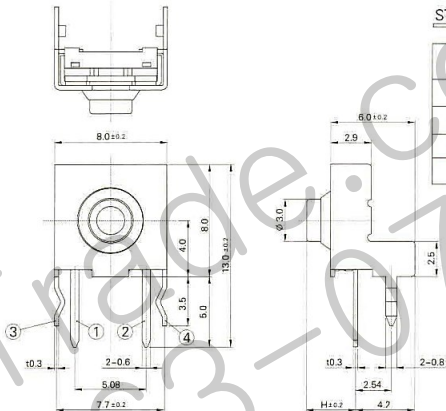

### STEM HEIGHT

MODEL	H(mm)
1110GVA	3.5
1110GVB	4.0
1110GVC	5.7
1110GVD	8.7

### SPECIFICATION

1. RATING : DC 12V 50mA
2. CONTACT RESISTANCE : 50mΩ MAX.
3. TRAVEL : 0.5 ± 0.2mm
4. BOUNCE : 10m SEC MAX.

MODEL	OPERATING FORCE	LIFE CYCLES
1110GV -1	130 ± 50gf	80,000CYCLE
1110GV -2	160 ± 50gf	80,000CYCLE
1110GV -4	300 ± 80gf	50,000CYCLE
1110GV -5	500 ± 100gf	50,000CYCLE

### CIRCUIT DIAFGAM

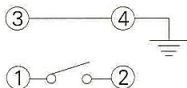

### P.C.B MOUNTING HOLES

