

1117

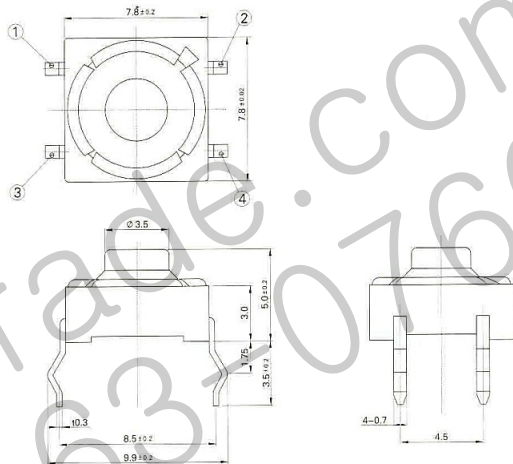

SPECIFICATION

1. RATING : DC 12V 50mA
2. CONTACT RESISTANCE : 1K Ω MAX.
3. TRAVEL : 1.0 \pm 0.2mm
4. BOUNCE : 20m SEC MAX.

5.

MODEL	OPERATING FORCE	LIFE CYCLES
1117 -1	120 \pm 30gf	100,000 CYCLE

CIRCUIT DIAGRAM



P.C.B MOUNTING HOLES

