

AUTOCAD GENERATED DRAWING. DON'T CHANGE BY HAND.

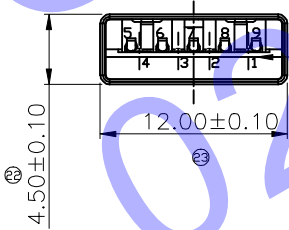

| REV. | ECN NO. | DESCRIPTION | DRAW | APPD. | DATE |
|------|---------|-------------|------|-------|------------|
| A0 | | NEW | 梁佳龙 | 谭军明 | 2017-01-15 |

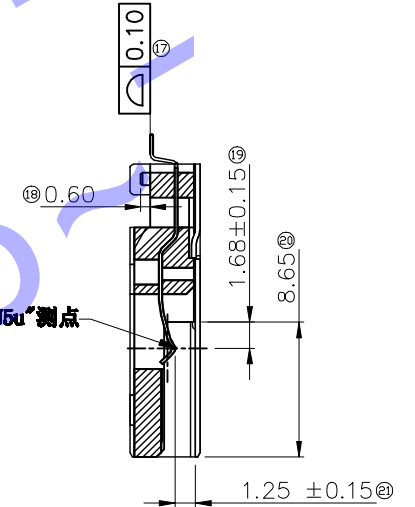
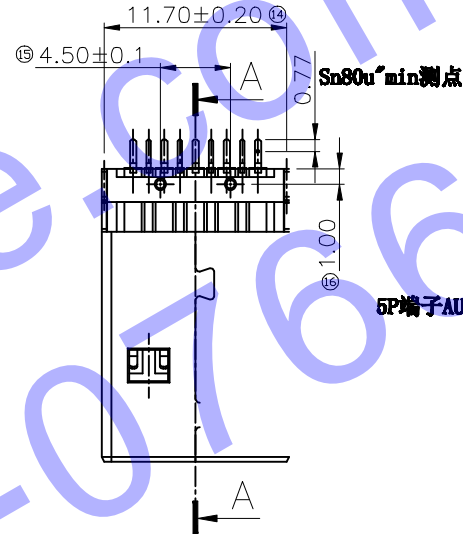
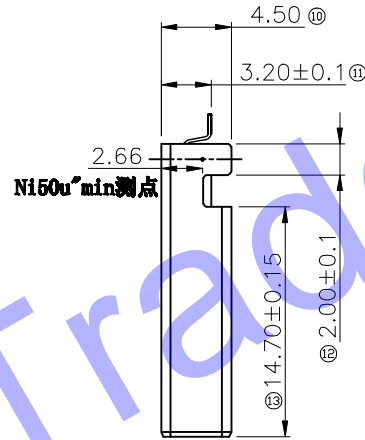
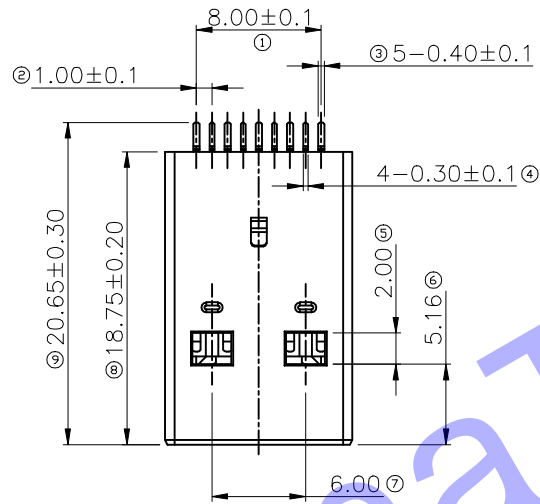
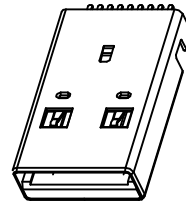

4P端子AU5u"
测点4.3MM距离

Notes:
 1) Environmental: -55°C to +105°C
 2) Electrical
 Voltage : 30VAC(R.M.S)
 Current Rating : 1.5 Ampere Min.
 Contact resistance : 30 Milliohms Max.
 Insulation resistance : 100 Megohms Min.
 Dielectric withstanding voltage :
 500 VAC IR:260"/10S

TABLE

| | | | | |
|-------------------|-------|------------|-----------------------------------------|-----------|
| MNB105U0500T | 9 | TERMINAL | C5191-H AU 5u" | |
| | 1 | SHELL | SPCC 50u" min Nickel | |
| | 1 | HOUSING | LCP UL94V-0; COLOR:BLUE | |
| PART NO. | | Q'TY | Material | FINISH |
| UNITS | SCALE | REV. | SHEET | |
| mm | 1:1 | A0 | 1 OF 1 | |
| GENERAL TOLERANCE | | DATE | TITLE: | |
| 0. ±0.30 | | 2017-01-15 | USB A/M 3.0 L=18.7 沉板3.2 外壳4.5 有柱 锡脚1.9 | |
| 0.0 ±0.25 | | DR. | H D C 有限公司 | |
| 0.00 ±0.20 | | 梁佳龙 | | |
| 0. ±5° | | CHK. | MAT'L | FINISH |
| 0.0 ±4° | | APPD. | SEE NOTES | SEE NOTES |
| | | | DWG.NO. | PART NO. |
| | | | A | SEE NOTES |
| | | | | SIZE |
| | | | | A4 |