

REV.	ECN NO.	DESCRIPTION	DRAW	CHECK	APPD.	DATE
X0		INITIAL RELEASE	SUN YUAN			2013-08-07

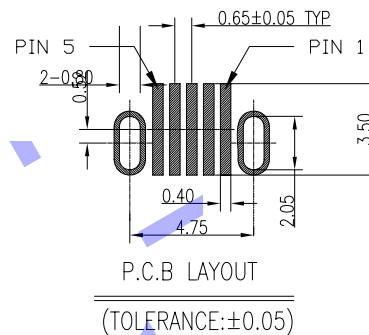

- NOTES:
- 1.DIMENSIONS:
THE ALL DIMENSIONS SHOULD BE CONTROLLED BY FAI
 - 2.MECHANICAL:
INSERTION FORCE: 35N MAX.
EXTRACTION FORCE:10N MIN(INITIAL),8~25N(AFTER)
DURABILITY: 10000 CYCLES MIN.
 - 3.ELECTRICAL:
CURRENT: 1A MIN WITH PIN2,3,4;1.8A MIN WITH PIN1 & 5
VOLTAGE: 30V MAX
WITHSTANDING VOLTAGE: 100V AC
CONTACT RESISTANCE: 30 mΩ MAX ;40 mΩ MAX AFTER 10000CYCLES
INSULATION RESISTANCE: 1000MΩ MIN
 - 4.ENVIRONMENTAL
TEMPERATURE RANGE -30°C ~ +80°C

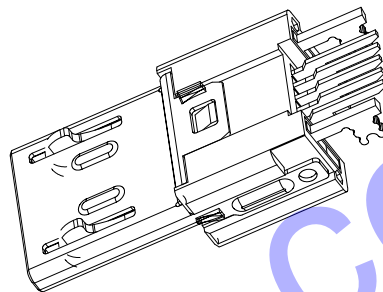
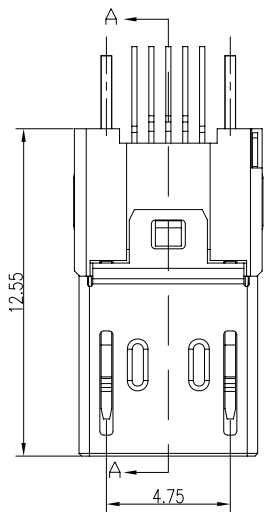
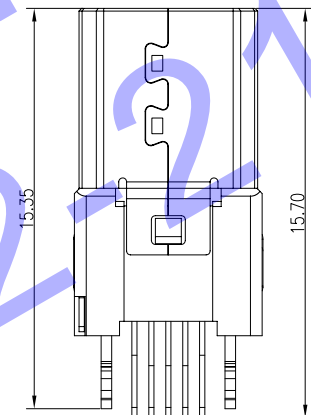
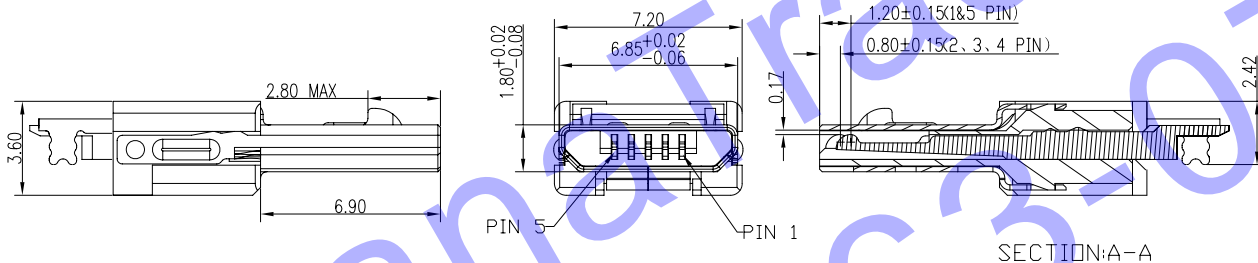

TABLE:

PRODUCT NO.	ITEM	PART NO.	PART NAME	Q'TY	Material
CNE071U0900U	1	PS210B8720	SHELL	1	SUS304R-1/2H ,Ni PLATED 50U"Min 鍍高溫可焊線:
	2	PS109B2360	CONTACT(1)	2	C5210R-H,T=0.20,Au 1u"MIN, 霧錫100u"MIN
	3	PS109B5490	CONTACT(3)	3	C5210R-H,T=0.20,Au 1u"MIN, 霧錫100u"MIN
	4	PS218B8730	LATCH	2	SUS301R-H, 可焊線50u"MIN.
	5	PP101B4300	HOUSING	1	LCP+30%GF-BLACK:

UNITS mm	SCALE 1:1	REV. X0	SHEET 1 OF 1	H D C 有限公司	
		DATE 2013-08-07	TITLE: MICRO USB B TYPE MALE 07款 SMT+DIP TYPE		
GENERAL TOLERANCE 0. ±0.30 0.0 ±0.25 0.00 ±0.25 0.° ±4° 0.0° ±3°		DR. SUN YUAN	CHK. /	MAT'L SEE TABLE	FINISH SEE TABLE
		APPD. /	DWG.NO. DWG-MUB 5M-195	A	PART NO. SEE TABLE
					SIZE A4