

5 4 3 2 1

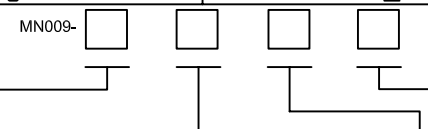

颜色 (主体)
 1: 黑色 6: 绿色
 2: 白色 7: 红色
 3: 贝吉色 0: 其它
 4: 灰色
 5: 蓝色

材质 (主体)
 1: PBT 2: LCP
 3: NL9T 4: NL6T
 5: ABS 6: NL66
 7: PPS 8: PVC
 9: PE
 0: 其它

外壳镀层
 1: 全金 6: 前镍后锡
 2: 全镍 0: 其它
 3: 全锡
 4: 前金后锡
 5: 前金后镍

端子镀层 (接合处)
 1: 10U² 6: 30U²
 2: 3U² 0: 其它
 3: 5U²
 4: 10U²
 5: 15U²

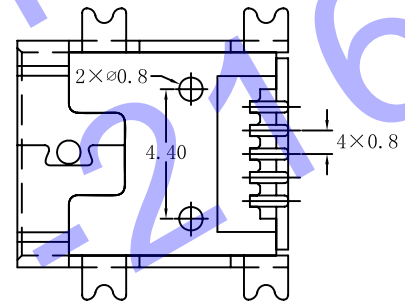
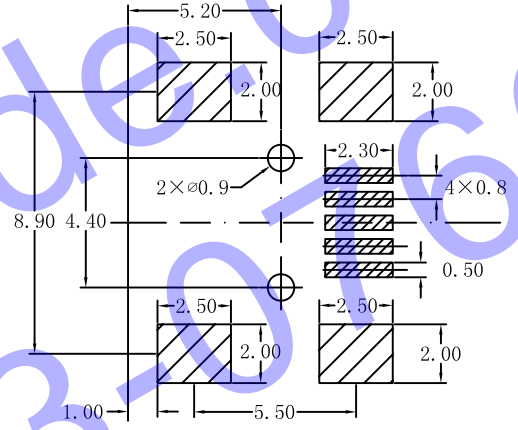
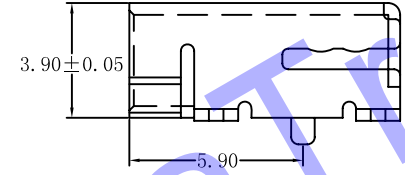
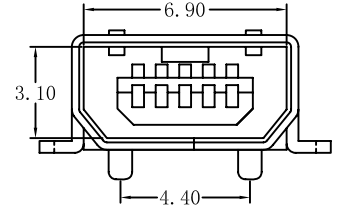
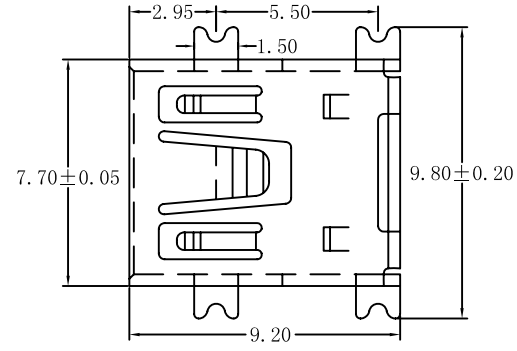

RECOMMENDED PCB LAYOUT

规格说明: Specifications:

- 电气特性: Electrical:
1. 额定电流: Current Rating
1.0A/contact terminal
 2. 额定电压: Voltage Rating
30V DC
 3. 接触阻抗: Contact Resistance
50 milliohms MAX
 4. 耐电压: Dielectric Withstanding Voltage:
300 V AC AT Sea Level
 5. 绝缘阻抗: Insulation Resistance:
100MEGA ohms MIN

物理性能: Mechanical:

1. 插拔力: Connector Mate and Unmate Force
Mate force: 3.0kgf (MAX)
Unmate force: 0.7kgf (MIN)
2. 端子保持力: Terminal Retention
0.5kgf (MIN)

原材料: Material:

1. 塑胶: Housing:
Hing Temperature Thermoplastics,
UL 94V-0 LCP Black
2. 端子: Contact: Copper Alloy C2680/C5191
3. 外壳: Shell: Copper Alloy C2680

电镀: Finish:

1. 端子: Contact: Plated Gold in Mating Area;
Tin On Solder Talls
2. 外壳: Shell:
Nickel Plating

设计 DRAW BY	杨帆	审核 DISCUSS BY		H D C 有 限 公 司	图名 DRAWING NO	MINI USB 5PF AB TYPE SMT		图号 SHEET NO	009	日期 DATE	2013.8.08	
校对 DISCUSS BY		比例 SCALE	1:1		客户 VERSION	数量 QUAN		备注 REMARK		版次 REMARK		张号 SHEET