

修改序号	修改说明	签名	日期
A/0			

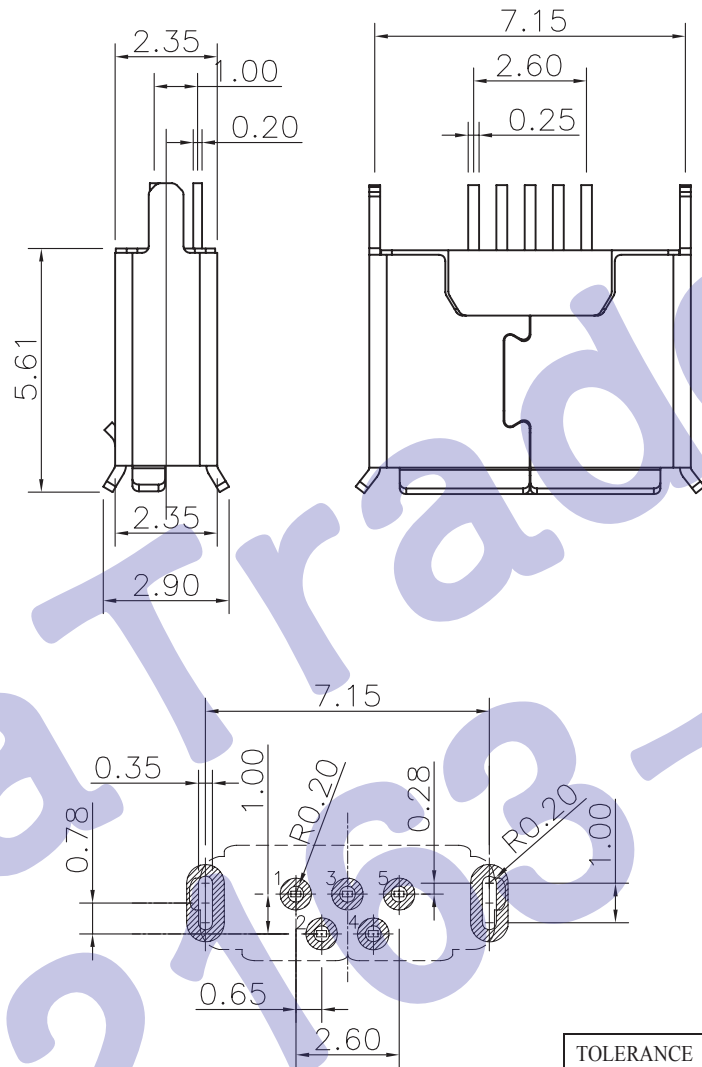
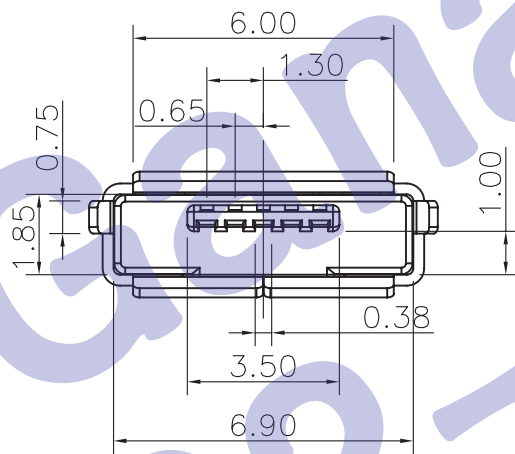
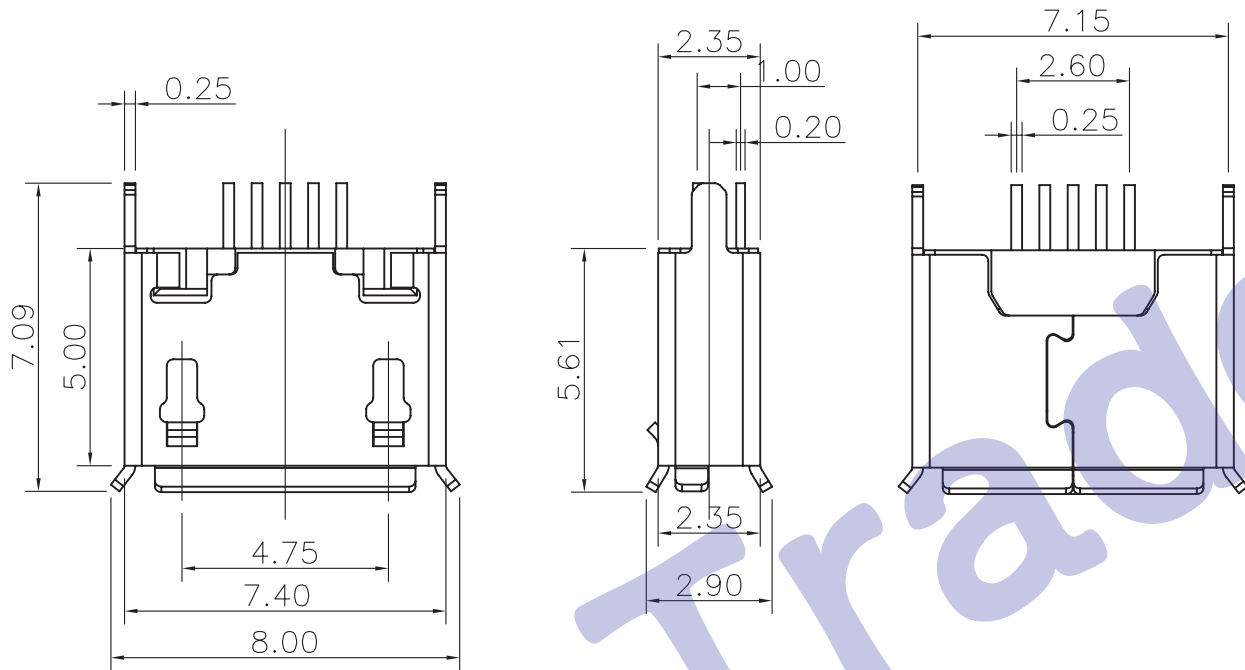

RECOMMENDED P.C.B LAYOUT

—NOTES—

1.Electrical:

Contact resistance:50m ohms max.
Dielectric withstanding voltage:
250V RMS.

Insulation resistance:
50M ohms min.

2.Mechanical:

MATE AND UNMATE FORCE:
MATE FORCE:3.0kg MAX
UNMATE FORCE:1.02kg MIN
Durability:3000cycles MIN.

3.Environment:

Operating Temperature:-20°to+85°.

4.FINISH:

TERMINAL: GOLD Plated Over NICKEL
Contact area,TIN ON
SOLDER TAIL AREA.

SHELL: BRASS WITH TIN Plated.

5.COLOR:

HOUSING: BLACK.

TOLERANCE UNLESS OTHERWISE SPECIFIED	
XXX	±0.10
XX	±0.20
X	±0.30
X°	±2°

HDC 有限公司

DRAM NO	134	DATE	DRAW NAME	
DWN		12.07.05	MICROUSB 5P180 度 DIP	
CHK				
APVD			P/N: MU134	

Third Angle Project	FINISH		UNIT	SCALE	WEIGHT	REV	SHEET
	MATERIAL		mm	1:1		A	1 OF 1