

MU148- □ □ □ □

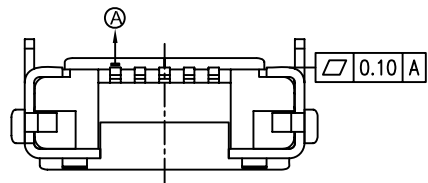

颜色 (主体)		材质 (主体)		外壳镀层		端子镀层 (接合处)	
1: 黑色	6: 绿色	1: PBT	2: LCP	1: 全金	6: 前镍后锡	1: 1U"	6: 30U"
2: 白色	7: 红色	3: NL9T	4: NL6T	2: 全镍	0: 其它	2: 3U"	0: 其它
3: 贝吉色	0: 其它	5: ABS	6: NL66	3: 全锡		3: 5U"	
4: 灰色		7: PPS	8: PVC	4: 前金后锡		4: 10U"	
5: 蓝色		9: PE		5: 前金后镍		5: 15U"	
		0: 其它					

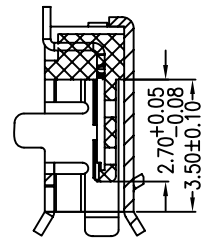

SECTION A-A'

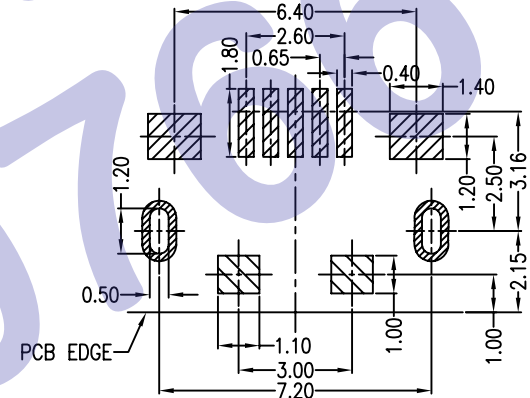
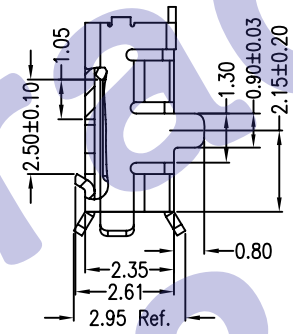
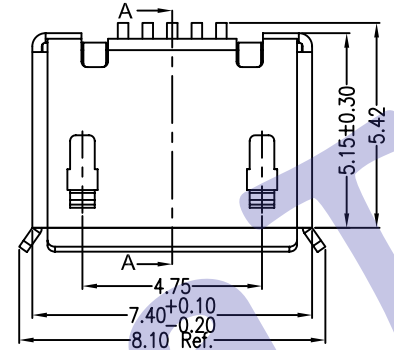

RECOMMENDED PCB LAYOUT

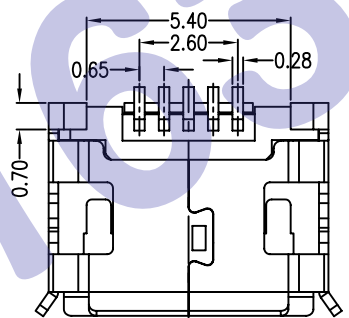
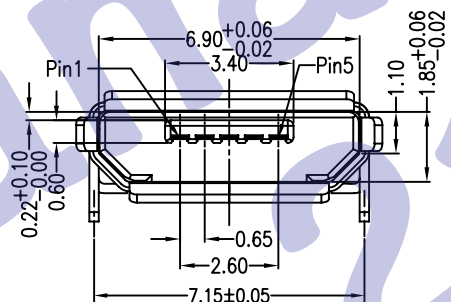

- Note:
- Material:
 - Housing: High temperature thermoplastic with g.f, UL94v-0
 - Contact: copper alloy, t=0.20mm
 - Shell: copper alloy, t=0.25mm
 - Specification:
 - Current rating: 1 A Max.
 - Dielectric withstanding voltage: 100 V(ac) for 1 min.
 - Contact resistance: 50 mΩ Max.
 - Insulation resistance: 100 MΩ Min.
 - Total mating force: 3.57 Kgf Max.
 - Total unmating force: 1.0 Kgf Min.0.81~2.05 A Kgf Min.after 10000 insertion/extraction cycles
 - Temperature range: -30°C~80°C

设计 DRAW BY	杨帆	审核 DISCUSS BY	
校对 DISCUSS BY		比例 SCALE	2:1

HDC有限公司

图名 DRAWING NO	MICRO USB B TYPEDIP 7.2 无柱短脚加长0.4卷边	图号 SHEET NO	148	日期 DATE	2011.5.20
客户 VERSION		数量 QUAN		备注 REMARK	
		版次 REMARK		张号 SHEET	1/1