

1 2 3 4 5 6 7 8

A

B

C

D

E

F

A

B

C

D

E

F

MU193-

颜色 (主体)		材质 (主体)		外壳镀层		端子镀层 (接合处)	
1: 黑色	6: 绿色	1: PBT	2: LCP	1: 全金	6: 前镍后锡	1: 1U"	6: 30U"
2: 白色	7: 红色	3: NL9T	4: NL6T	2: 全镍	0: 其它	2: 3U"	0: 其它
3: 贝吉色	0: 其它	5: ABS	6: NL66	3: 全锡		3: 5U"	
4: 灰色		7: PPS	8: PVC	4: 前金后锡		4: 10U"	
5: 蓝色		9: PE	0: 其它	5: 前金后镍		5: 15U"	

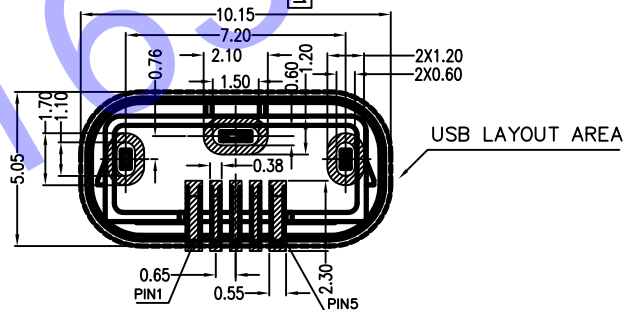
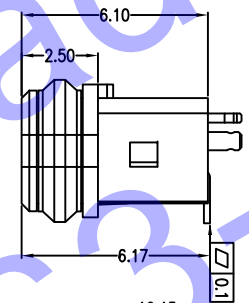
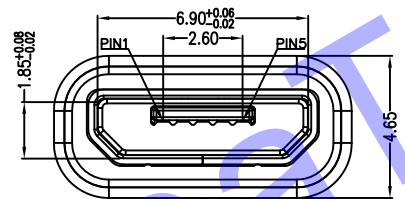
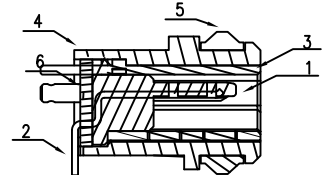
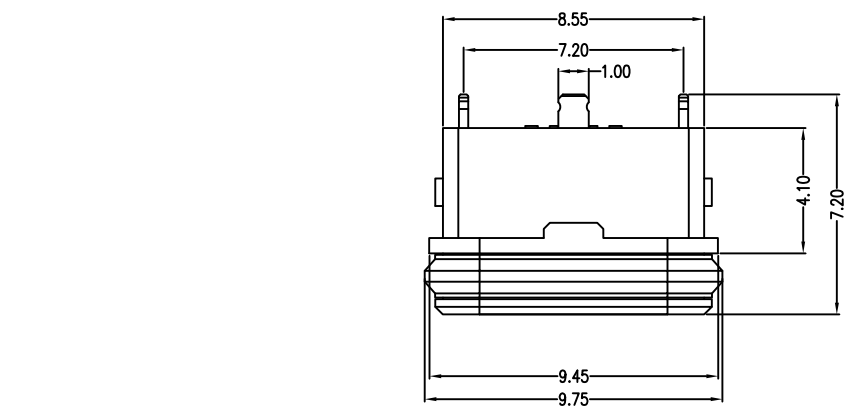
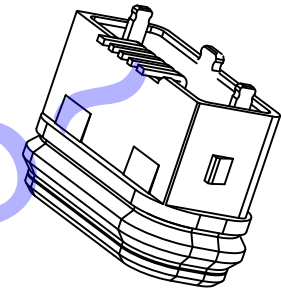

RECOMMEND PCB LAYOUT
PCB图仅供参考

Note:

- Material:
 - Housing: High temperature thermoplastic
 - Contact: copper alloy, t=0.20mm
 - Shell: SUS304, t=0.30mm
 - cover: High temperature thermoplastic
 - out Shell: SUS304 T=0.25
 - Ring: SILICON
 - Epoxy: Epoxy
- Specification:
 - Current rating: 1,5PIN 2.0A Max/2,3,4PIN 1A Max.
 - Dielectric withstanding voltage: 100 V(ac) for 1 min.
 - Contact resistance: 30 mΩ, Max.
 - Insulation resistance: 100 MΩ, Min.
 - Total mating force: 3.57 Kgf Max.
 - Total unmating force: 1.0 Kgf Min.
 - Temperature range: -30°C~80°C
 - Waterproof: IPX68.

TOLERANCES .X ±0.38 .XX ±0.25 ANGULAR ±3°	单位 UNITS SCALE	MM 2:1	版次 REMARK DATE	A0 2013.5.8	H D C 有限公司		品名 NAME MIRCO USB 5S B型防水180 DIP SMT	料号 PART NO. MU193	客户 VERSION	
设计 DRAW BY	杨帆	校对 DISCUSS BY	审核 DISCUSS BY	FAN	张号 SHEET	1/1				

1 2 3 4 5 6 7 8